

DIMENSIONS

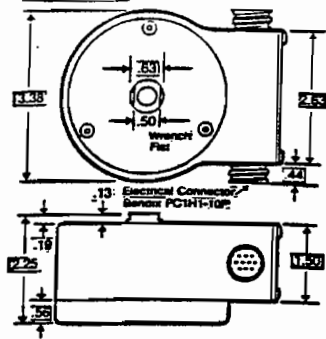

MECHANICAL CONFIGURATION

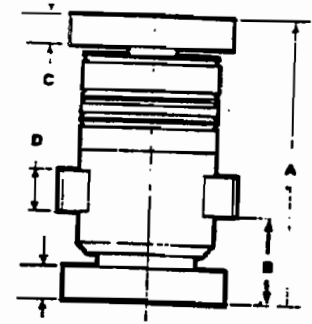
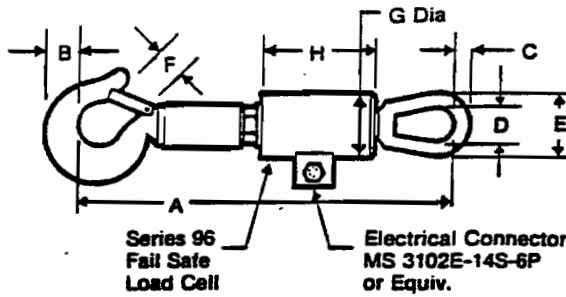

Your Custom Weighing Application . . . is our standard job!

- UNIQUE SUSPENSION?
- SPECIAL LOAD CELLS?
- HARSH ENVIRONMENT?
- EXCEPTIONAL CONTROL?
- HIGH ACCURACY?
- QUICK DELIVERY?



TOROID CORPORATION

P.O. BOX 1435
HUNTSVILLE, ALABAMA 35807
(256) 837-7510
FAX (256) 837-7512

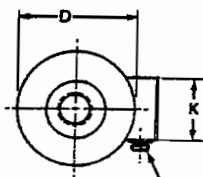
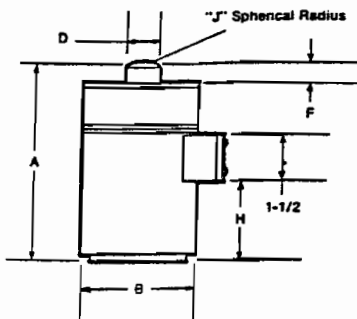

CONNECTOR OR
TEN FOOT CABLE
OPTIONAL

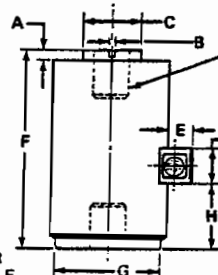

T TYPICAL
BOTH ENDS

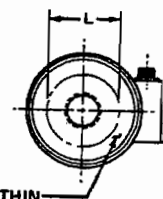

HOLES CAN
BE DRILLED WITHIN
THIS AREA TO RECEIVE
LOCKING SCREWS
MAXIMUM DEPTH OF HOLES IS-M-
DIMENSION -P- IS THREAD SIZE

TOROID SERIES 35 LOAD CELL

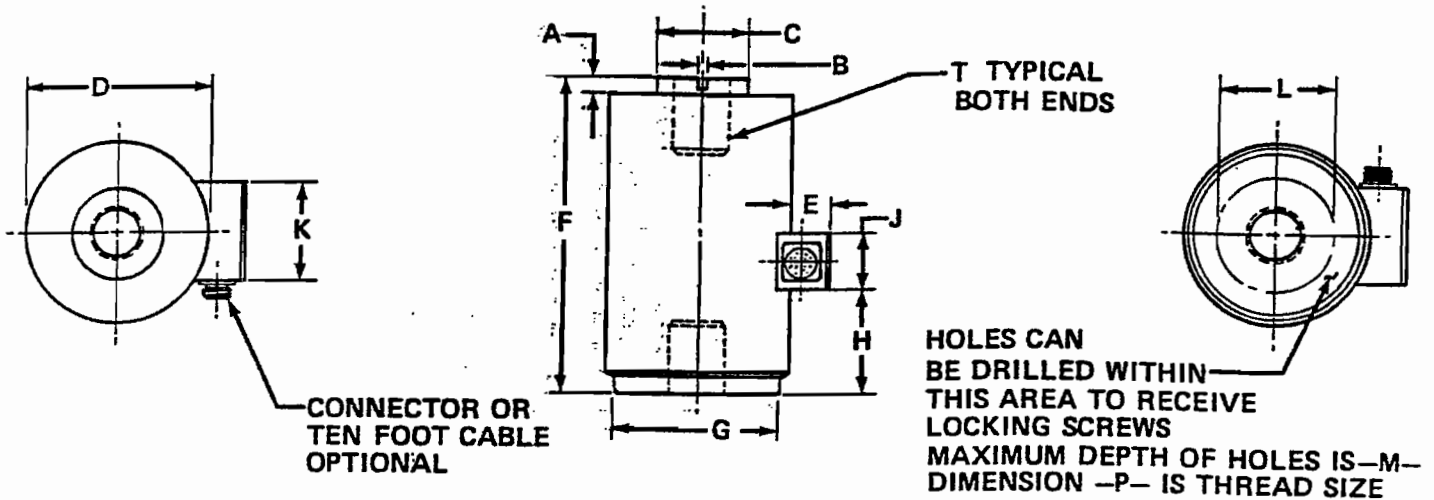

RANGE	A	B	C	D	E	F	G	H	J	K	L	M	T THREAD	P THREAD SIZE
100-3,000	.24	.06	.70	3.00	.78	4.44	2.63	1.13	1.50	2.63			1/2-20 UNF-2B x .66 DP	
5,000-10,000	.28	.13	1.42	3.50	.78	5.94	2.95	1.85	1.50	2.63	2.50	.50	1-14 UNS-2B x .13 DP	
25,000	.44	.19	2.50	5.00	1.00	8.50	4.45	2.81	1.50	2.63	2.38	.38	1 1/2-12 UN-2B x 2.0 DP	3/8-24 UNF 2B
50,000	.56	.25	3.25	6.50	1.06	11.44	5.88	3.70	1.50	2.63	2.38	.38	2-12 UN-2B x 2.63 DP	3/8-24 UNF 2B
100,000	1.06	.38	5.00	9.00	1.19	17.75	8.10	6.25	1.50	2.63	4.00	.75	3-8 UN-2B x 5.13 DP	1/2-20 UNF 2B
200,000	1.25	.50	6.00	12.00	1.22	22.00	10.13	10.75	1.50	2.63	5.00	1.00	4-8 UN-2B x 5.63 DP	5/8-16 UNF 2B
250,000	1.25	.50	6.00	12.00	1.22	22.00	10.13	10.75	1.50	2.63	5.00	1.00	4-8 UN-2B x 5.63 DP	5/8-16 UNF 2B
300,000	1.25	.50	6.00	12.00	1.22	24.00	8.20	8.00	1.50	2.63	5.50	1.13	4-8 UN-2B x 5.63 DP	3/4-16 UNF 2B
500,000	1.40	.50	7.00	12.00	1.22	25.00	10.75	11.75	1.50	2.63	5.50	1.13	4-1/2-8 NS-2B x 5.63 DP	3/4-16 UNF 2B
500,000	1.45	.50	9.50	14.00	1.25	30.00	11.50	12.00	1.50	2.63	5.50	1.13	5 1/2-8 UN-2B x 6.4 DP	3/4-16 UNF 2B
750,000	1.65	.63	10.00	18.00	1.25	34.00	15.00	14.00	1.50	2.63	5.50	1.13	7-4 NS-2B x 7.5 DP	3/4-16 UNF 2B
1,000,000	1.65	.75	11.50	18.00	1.25	38.00	15.00	18.00	1.50	2.63	8.00	1.13	7-4 NS-2B x 7.5 DP	3/4-16 UNF 2B
1,000,000	1.65	.75	14.00	30.00	1.25	50.00	20.00	20.00	1.50	2.63	8.00	1.13	8-4 NS-2B x 11.0 DP	3/4-16 UNF 2B

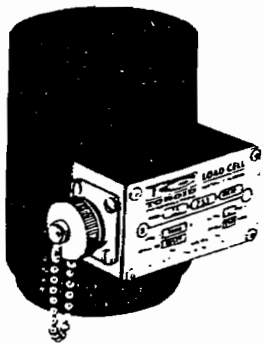

SINGLE BRIDGE WITH CONNECTOR

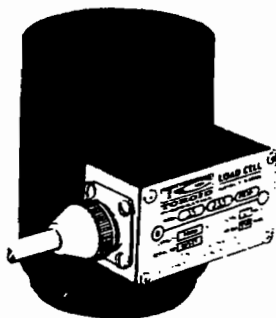

SINGLE OR DOUBLE BRIDGE WITH CABLE

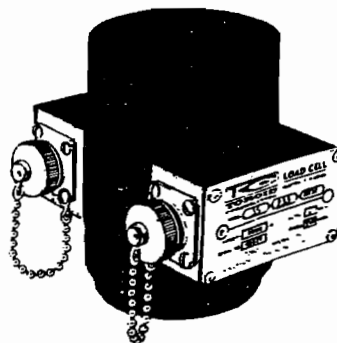

DOUBLE BRIDGE WITH CONNECTOR

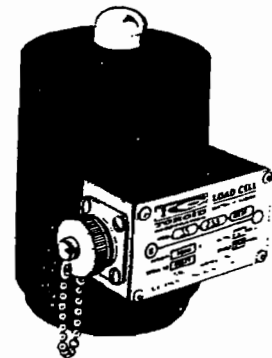

SINGLE BRIDGE OR DOUBLE BRIDGE WITH LOAD BUTTON

P. O. BOX 1435 HUNTSVILLE, ALABAMA 35807 TELEPHONE (256) 837-7510

225 WYNN DRIVE HUNTSVILLE, ALABAMA 35805 FAX (256) 837-7512

TOROID SERIES 35 LOAD CELL SPECIFICATIONS

SPECIFICATIONS

	CLASS NO. 1	CLASS NO. 2	CLASS NO. 3
FULL SCALE OUTPUT	± .10% F.S.	± .25% F.S.	± .25% F.S.
NON-LINEARITY	± .05% F.S.	± .10% F.S.	± .17% F.S.
HYSTERESIS	± .02% F.S.	± .02% F.S.	± .07% F.S.
REPEATABILITY	± .02% F.S.	± .02% F.S.	± .05% F.S.
ZERO LOAD OUTPUT SHIFT WITH TEMPERATURE PER °F	± .0015% F.S.	± .0025% F.S.	± .0025% F.S.
FULL SCALE OUTPUT SHIFT WITH TEMPERATURE PER °F	± .0008% F.S.	± .005% F.S.	± .005% F.S.

GENERAL SPECIFICATIONS (COMMON TO ALL LOAD CELLS IN THIS SERIES)

RECOMMENDED INPUT VOLTAGE	10 VOLTS AC OR DC
INPUT RESISTANCE AT 77°F (OHMS)	350 ± 1.5 OHMS
OUTPUT RESISTANCE AT 77°F (OHMS)	350 ± 3.5 OHMS
MAXIMUM INPUT VOLTAGE	20 VOLTS AC OR DC
COMPENSATED TEMPERATURE RANGE	+ 30° TO 130°F
MAXIMUM SAFE EXPOSURE TEMPERATURE	275°F
SAFE OVERLOAD	150%
MAXIMUM OVERLOAD	300%
INSULATION RESISTANCE AT 77°F	5000 MEGOHMS
ZERO LOAD OUTPUT @ 77°F	1%

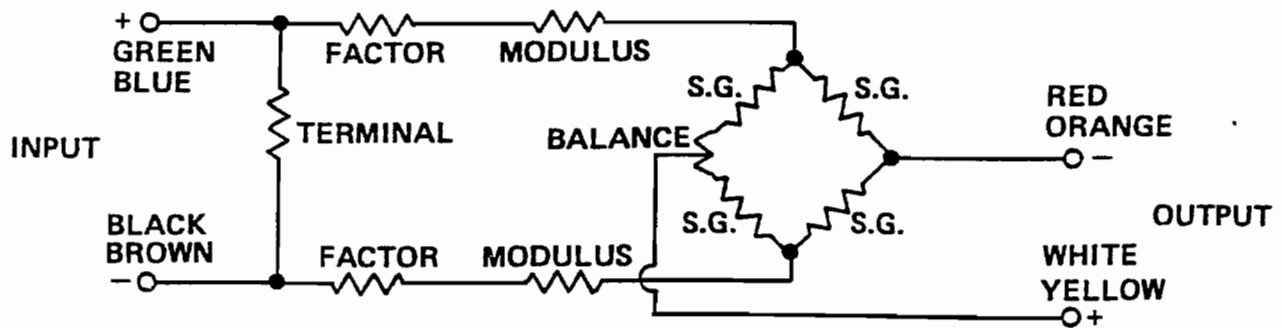

ORDERING INFORMATION

CLASS OF SERVICE

T = TENSION
C = COMPRESSION
U = UNIVERSAL

BRIDGE RESISTANCE

1 = 120 Ohm
2 = 350 Ohm
3 = OTHER

CLASS

1 = .05%
2 = .10%
3 = .25%

MODEL NO.

3 5 U

1 3 3

1 A

FACTORY USE ONLY
SPECIFICATION OR SYSTEM

NUMBER OF BRIDGES

1 = SINGLE
2 = DOUBLE
3 = TRIPLE
4 = N (4 OR MORE)

MV/VOLT RATING

1 = 1 mv/VOLT
2 = 2 mv/VOLT
3 = 3 mv/VOLT
4 = OTHER

CONNECTIONS

A = CONNECTOR (SPEC)
B = CABLE -10' 0"

Where the Series 35 is used

- Tension, compression and universal service.
- For general purpose or high accuracy applications. The Series 35 can be built to a wide range of accuracies. Specials are also available.
- Rugged force measurement or weighing applications due to overload characteristics.
- Interchangeable with most comparable quality load cells installed previously.
- Static rocket firings.
- Batch and continuous weighing systems.
- Where calibration checks are continuously being made.
- Cyclic test loads up to one million cycles. Not to be confused with our 100 million dynamic load cells.
- Where long term stability and no creep is required.
- Where static overloads do not exceed 300% of the rated cell capacity (Performance may be affected at 150%).

- When overloads or shock loads exceed 300% of the capacity of the load cell. Performance will be affected at 150% capacity or more.

How to Apply the Series 35

1. Evaluate the force range. The "35" can effectively be sized from 100# to 1,000,000# or more.
2. Evaluate possible overloads.
3. Determine the accuracy required.
4. Select the temperature compensation range in which you are going to use the Series 35.
5. Select the physical mounting hardware and electrical connections.

OPTIONS TO THE SERIES 35

- Special millivolt/volt output.
- Different accuracies--note specifications.
- High level output (1-10 volt) available at extra cost.
- Special bridge configuration up to four bridges.
- Different resistance values.
- Different temperature compensation specifications.
- Connectors to meet your needs. Some connectors are at additional cost.
- Metal dust caps for connectors are an optional extra.
- Cable of different lengths and types, as required.
- Mounting hardware including load buttons. Mounting plates, tension fixtures, flexures, and flexure rods.
- Application assistance by Toroid's qualified engineering staff.

Caution should be used with the Series 35

- When high cyclic loads (10 million or more cycles) are to be encountered. Toroid provides a complete line of fatigue type load cells.
- Where load profile is requisite. There are lower profile cells available from Toroid.
- Under larger barometric pressure change. The lower capacity Series 35 (as with other makes) will show a marked affect with a change of pressure on the diaphragm. This area should be evaluated and perhaps a Series 36 be utilized.
- If the temperature range varies over 120°F in a short time period. The Series 35 is compensated over the 120°F range and has a maximum exposure range of 275°F.

TOROID CORPORATION

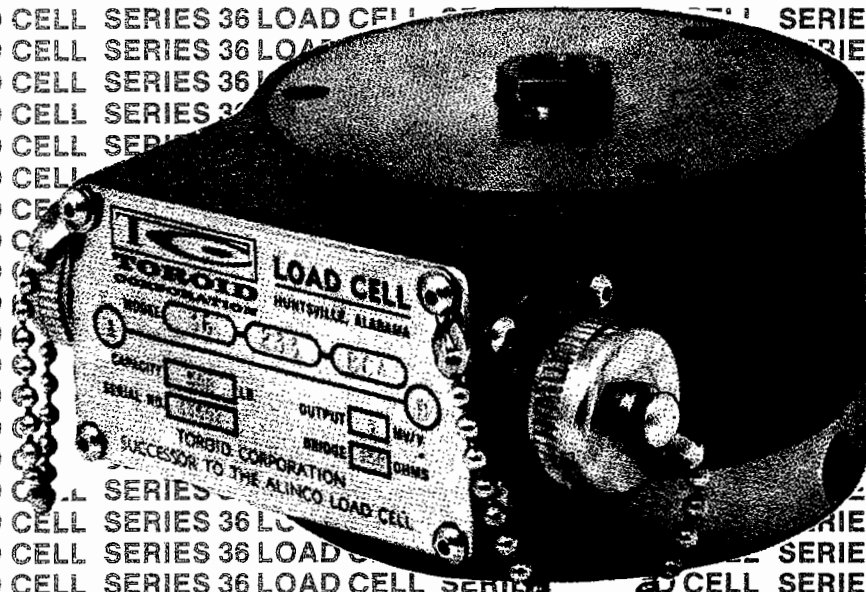

- COMBINED ERROR LESS THAN 0.07%
- OVERLOADS TO 500% WITH NO PERFORMANCE DEGRADATION
- BAROMETRIC COMPENSATION
- TENSION/COMPRESSION LOADING
- HERMETICALLY SEALED
- STAINLESS STEEL CONSTRUCTION

SPECIFICATIONS

STANDARD RANGES:	25 lbs. 100 lbs. 500 lbs. 50 lbs. 200 lbs. 750 lbs. 75 lbs. 300 lbs. 1,000 lbs.
FULL SCALE OUTPUT:	2.00 mv/v \pm .10% 3.00 mv/v \pm .10%
INPUT RESISTANCE AT 77° F:	350 ohms \pm 3.5 ohms
OUTPUT RESISTANCE AT 77° F:	350 ohms \pm 3.5 ohms
NONLINEARITY:	\pm .05% F.S. max.
HYSTERESIS:	\pm .03% F.S. max.
NONREPEATABILITY:	\pm .02% F.S. max.
CREEP:	\pm .03% F.S. max./first 20 min.
COMBINED ERROR (Nonlinearity, Hysteresis, and Nonrepeatability):	\pm .07% F.S. max. (See note below).
ZERO LOAD OUTPUT AT 77° F:	\pm 1% F.S.
RECOMMENDED INPUT VOLTAGE:	10 volts AC or DC.
MAX. INPUT VOLTAGE:	20 volts AC or DC.
ZERO LOAD OUTPUT SHIFT WITH TEMPERATURE:	\pm .12% F.S./100° F
FULL SCALE OUTPUT SHIFT WITH TEMPERATURE:	\pm .08% F.S./100° F
COMPENSATED TEMPERATURE RANGE:	+30° F to +130° F.
MAX. SAFE EXPOSURE TEMPERATURE:	+275° F.
ZERO LOAD OUTPUT CHANGE WITH AMBIENT PRESSURE CHANGE:	Inherently insensitive to ambient pressure changes between 0 and 30 psia.
NATURAL FREQUENCY:	1,000 to 3,500 cps (Depending on range).
DEFLECTION:	.005 inch max.
ERROR DUE TO ANGULAR LOADING:	.10% max. at 3°.
SAFE OVERLOAD:	500% F.S.
MAXIMUM OVERLOAD:	1,000% F.S. min.
INSULATION RESISTANCE AT 77° F:	Greater than 5,000 megohms.
WEIGHT:	Approx. 4 lbs.

NOTE: For 25 and 50 lb. ranges combined error specification applies only in direction of standardization. Specifications normally standardized in compression on all ranges.

Patent No. 3272006

Specifications Subject To Change Without Notice

DIMENSIONS

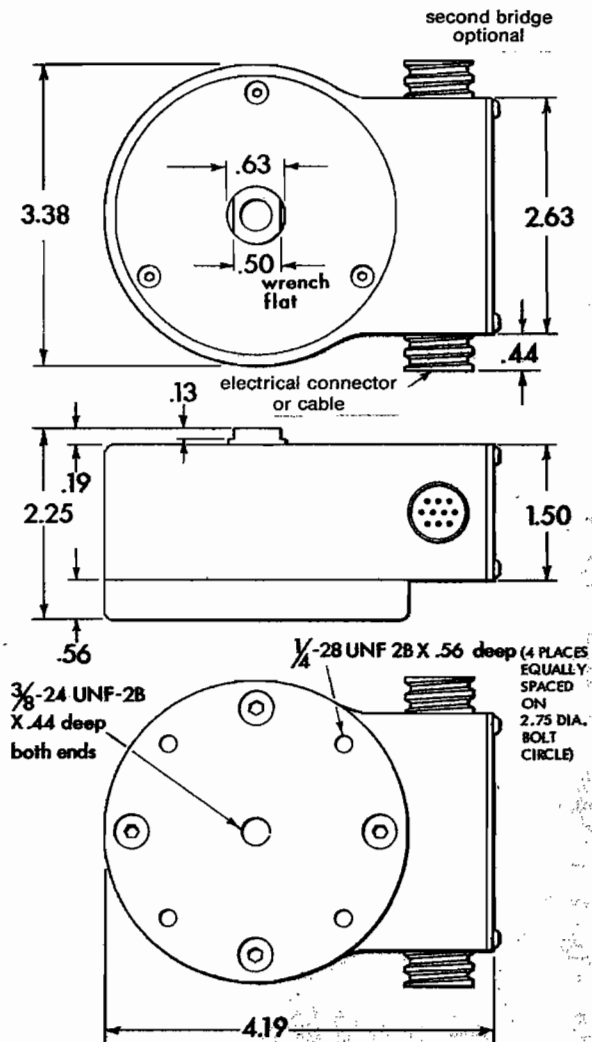

P. O. BOX 1435
HUNTSVILLE, ALABAMA 35807



225 WYNN DRIVE
HUNTSVILLE, ALABAMA 35805

TOROID SERIES 38 LOAD CELL

SPECIFICATIONS

Standard Ranges	5,000 – 300,000 Pounds
Bridge Configuration	350 Ohm Single
Standard Electrical Connection	10 Feet of Cable
Input Terminal Resistance	350 ± 3.5 Ohms
Output Terminal Resistance	350 ± 5 Ohms
Recommended Excitation Voltage	12 Volts AC or DC
Maximum Excitation Voltage	20 Volts AC or DC
Rated Output	2 MV/Volt Input
Calibration Accuracy	0.10% of 2MV/V in Comp.
Zero Load Output Shift with Temperature	0.15% F.S./100 F.
Zero Balance	± 1.0% F.S.
Full Scale Output Shift with Temperature	0.08% F.S./100 F.
Compensated Temperature Range	15 – 115 F.
Non-Linearity	0.05% F.S. in Compression
Hysteresis	0.02% F.S.
Non-Repeatability	0.02% F.S.
Safe Overload Rating	150% of Rated Capacity
Insulation Resistance	5000 Megohms Bridge to Ground, 2000 Megohms Cable Shield to Ground

Specifications Subject to Change Without Notice

DIMENSIONS

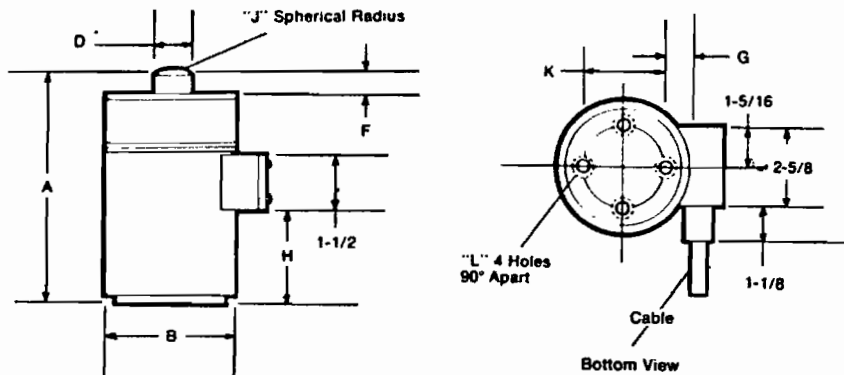

CAPACITY

	A	B	D	F	G	H	J	K	L
5,000	6.13	3.50	1.48	.75	.78	1.87	6	2.37	3/8-24NF-2X3.8 DP
10,000	6.13	3.50	1.42	.75	.78	1.87	6	2.37	3/8-24NF-2X3.8 DP
20,000	7.50	4.50	1.25	.75	.87	3.44	12	2.37	3/8-24NF-2X3.8 DP
50,000	7.50	4.50	1.25	.75	.87	3.44	12	2.37	3/8-24NF-2X3.8 DP
100,000	9.13	6.00	1.75	1.06	1.03	4.75	18	4.00	1/2-20NF-2X3.4 DP
200,000	11.62	8.00	2.50	1.06	1.13	6.25	18	5.00	5/8-18NF-2X1 DP
300,000	17.50	10.00	4.00	1.31	1.25	8.13	24	6.00	3/4-10NC-2X1 DP

TOROID SERIES 38 LOAD CELL

- COMPRESSION LOADING
- LOAD BUTTON INTEGRAL TO SENSING ELEMENT
- HIGH ACCURACY
- SUPERB INDUSTRIAL WEIGHING COMPONENT
- CAPACITIES: 5,000# - 300,000# STANDARD - HIGH RANGES TO 1,000,000 LBS.

The Toroid 38 Series Load Cell is designed for inherent accuracy. That is, each element is constructed and stressed configured to provide a .05 linearity, .02 repeatability, and hysteresis without the need for any electrical compensating network. While this is a more expensive way of manufacturing a load cell, the increase of element mass provides the user with a more stable platform for load carrying capability, less affected by transverse or moment loads.

You will find the Series 38 not only weighs more but does more.

HOW TO APPLY THE 38

The Series 38 compression only load cell has been used many years as the key component in the industrial weighing field. Part of the Series 38 is a built-in load button which reduces installation time and enhances the performance. The spherical loading surface is designed for minimum friction wear in each load range and highly heat treated for minimum deformation.

The following applications utilize the Series 38 to good advantage:

- TANK AND HOPPER WEIGHING
- RAILROAD TRACK SCALES
- MOTOR TRUCK SCALES
- FLOOR TYPE WEIGHING SYSTEMS
- SPECIAL COMPRESSION APPLICATIONS

Coupled with Toroid's hardened mounting plates, this unit provides the ideal weight measuring device for your application.

ORDERING INFORMATION

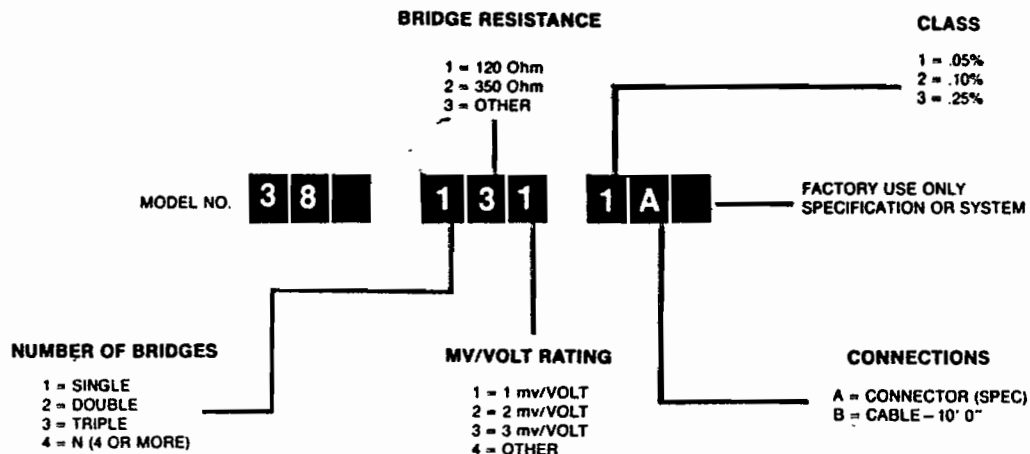

OPTIONS TO THE SERIES 38

There are many variations of the Series 38 which are noteworthy and can be discussed with Toroid. Some of these are as follows:

- SPECIAL MILLIVOLT/VOLT OUTPUT
- HIGH LEVEL OUTPUT (1-10 VOLT) AVAILABLE AT EXTRA COST
- SPECIAL BRIDGE CONFIGURATION UP TO FOUR BRIDGES
- DIFFERENT RESISTANCE VALUES
- CONNECTORS TO MEET YOUR NEEDS. SOME CONNECTORS ARE AT ADDITIONAL COST.
- METAL DUST CAPS FOR CONNECTORS ARE AN OPTIONAL EXTRA
- CABLE OF DIFFERENT LENGTHS, PACKAGE SIZE AND TYPES, AS REQUIRED
- MOUNTING HARDWARE INCLUDING MOUNTING PLATES, FLEXURES AND FLEXURE RODS
- APPLICATION ASSISTANCE BY TOROID'S QUALIFIED ENGINEERING STAFF

TOROID SERIES 38 LOAD CELL

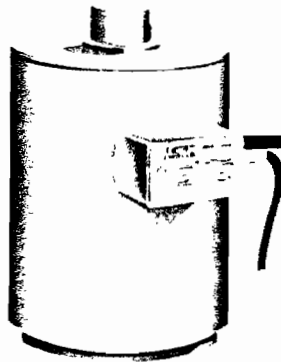

Custom 38

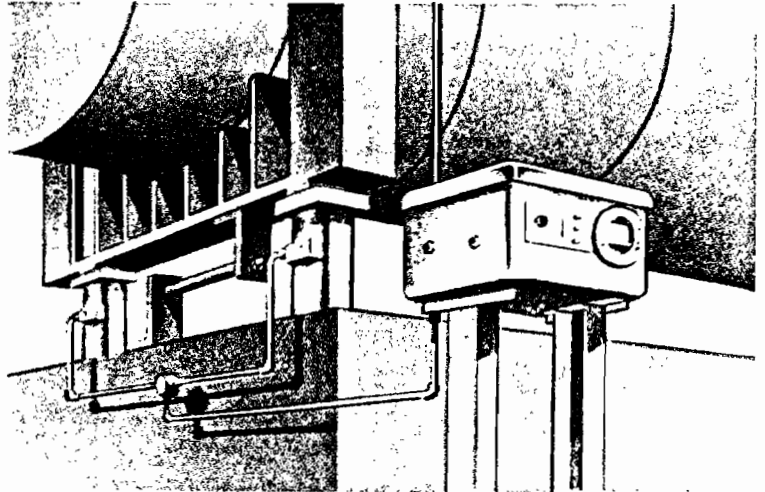

Continuous Level Monitoring System

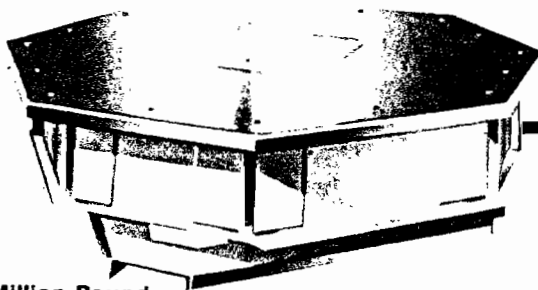

Half Million Pound Slag Platform

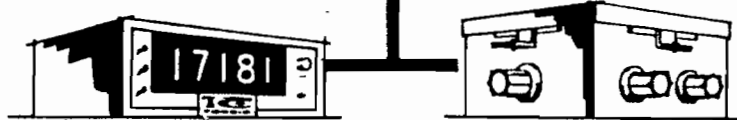

PROCESS CONTROL

DATA SYSTEM

COMPUTER

MICRO-PROCESSING

The Toroid Series 38 provides the "heart" for many industrial weighing applications today. You, too, can be the satisfied owner of an electronic weighing system with the

Series 38 Load Cell providing the foundation. Simply contact your local Toroid representative or call:



P.O. Box 1435 * Huntsville, Alabama 35807

Phone (256) 837-7510 * Fax (256) 837-7512

TOROID SERIES 40 LOAD CELL

DIMENSIONS

CAPACITY POUNDS	DIMENSION—INCHES														P THREAD SIZE	R
	A	B	C	D	E	F	G	H	J	K	L	M	N			
10,000	2.870	1.785	1.250	6.000	2.340	0.375	3.250	1.625	2.000	0.900	0.600	1.500	3.000	1/2-20 UNF-2B	0.625	
25,000	2.870	1.785	1.250	6.000	2.340	0.375	3.250	1.625	2.000	0.900	0.600	1.500	3.000	1/2-20 UNF-2B	0.625	
50,000	2.870	1.785	1.250	6.000	2.340	0.375	3.250	1.625	2.000	0.900	0.600	1.500	3.000	1/2-20 UNF-2B	0.625	
100,000	4.125	3.010	2.310	6.000	2.960	0.500	5.000	2.500	2.000	0.900	0.600	1.500	3.500	3/4-16 UNF-2B	0.750	
200,000	6.000	4.000	3.130	17.00	3.900	1.000	7.250	3.630	2.000	0.900	0.600	1.500	4.500	3/4-16 UNF-2B	0.750	
300,000	6.000	4.000	3.130	17.00	3.900	1.000	7.250	3.630	2.000	0.900	0.600	1.500	4.500	3/4-16 UNF-2B	0.750	
500,000	6.500	3.000	3.690	17.00	4.130	0.560	9.000	4.500	2.000	0.900	0.600	1.500	4.730	3/4-16 UNF-2B	0.750	

TOROID MODEL 40 LOAD CELL

10/01/93

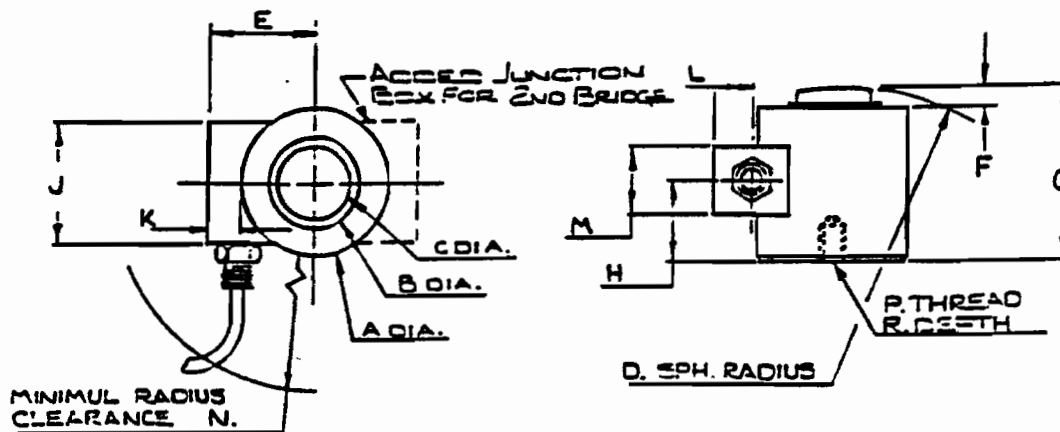

ORDERING INFORMATION

CLASS OF SERVICE

C - COMPRESSION

BRIDGE RESISTANCE

- 1 - 120 Ohm
- 2 - 350 Ohm
- 3 - OTHER

CLASS

- 1 - .05%
- 2 - .15%

MODEL NO.

4 0 C

1 3 3

1 A

FACTORY USE ONLY
SPECIFICATION OR SYSTEM

NUMBER OF BRIDGES

- 1 - SINGLE
- 2 - DOUBLE
- 3 - TRIPLE
- 4 - N (4 OR MORE)

MV/VOLT RATING

- 1 - 1 mv/VOLT
- 2 - 2 mv/VOLT
- 3 - 3 mv/VOLT
- 4 - OTHER

CONNECTIONS

- A - CONNECTOR (SPEC)
- B - CABLE -10' 0"

TOROID SERIES **40** LOAD CELL

SPECIFICATIONS

<i>STANDARD RANGES</i>	5,000 - 500,000 Pounds
<i>BRIDGE CONFIGURATION</i>	480 Ohm Single
<i>STANDARD ELECTRICAL CONNECTION</i>	10 Foot Cable
<i>INPUT TERMINAL RESISTANCE</i>	450 +/- 1%
<i>OUTPUT TERMINAL RESISTANCE</i>	480 +/- 1%
<i>RECOMMENDED EXCITATION VOLTAGE</i>	15 Volts AC or DC
<i>MAXIMUM EXCITATION VOLTAGE</i>	20 Volts AC or DC
<i>RATED OUTPUT</i>	2 MV/Volt Input +/- 0.10% F.S.
<i>ZERO LOAD OUTPUT SHIFT WITH TEMPERATURE</i>	0.13% F.S./100° F
<i>ZERO BALANCE</i>	+/- 1.0% F.S.
<i>FULL SCALE OUTPUT SHIFT WITH TEMPERATURE</i>	+/- 0.08% F.S./100° F
<i>COMPENSATED TEMPERATURE RANGE</i>	15° - 115° F
<i>NON-LINEARITY</i>	0.05% F.S. Class 1 (0.15% Class 2)
<i>HYSTERESIS</i>	0.03% F.S.
<i>NON-REPEATABILITY</i>	0.02% F.S.
<i>SAFE OVERLOAD RATING</i>	150% of Rated Capacity
<i>MAXIMUM OVERLOAD RATING</i>	300% of Rated Capacity
<i>INSULATION RESISTANCE</i>	5000 Megohms Bridge to Ground 2000 Megohms Cable Shield to Ground

See "OPTIONS" for alternate specifications

TOROID SERIES **40** LOAD CELL

FEATURES:

- o Robust design
- o Compression loading only
- o Inherent off-load capability
- o Hermetically sealed
- o Medium profile construction
- o Easily repairable

OPTIONS:

- o Additional bridges
- o 0 - 10 volt junction box amplifier
- o Selection of millivolt output value
(No additional charge)
- o Selection of resistance value
(No additional charge)
- o Linearity (accuracy)
- o Stainless steel construction
- o Special cable or connectors
- o Special capacities



P.O. BOX 1435 HUNTSVILLE, ALABAMA 35807

225 WYNN DRIVE HUNTSVILLE, ALABAMA 35805

TOROID

Series 47 Flat Load Cell

FEATURES

The following are features and benefits of the TOROID Series 47 Flat Load Cell:

- Robust Design
- Tension and Compression Loading
- Inherent Off-load Capability
- Low-Profile Construction
- Ground Base Plate Not Required
- Easily Repairable

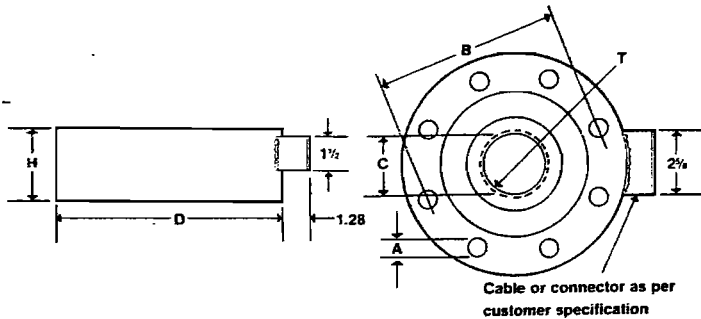

SPECIFICATIONS

Bridge Configuration	350 Ohm Single
Standard Electrical Connection	10 feet of cable
Input Terminal Resistance	350 ± 1.5 Ohms
Output Terminal Resistance	350 ± 3.5 Ohms
Recommended Excitation Voltage	12 volts AC or DC
Maximum Excitation Voltage	20 Volts AC or DC
Rated Output	2 or 3 Mv/Volt Input
Calibration Accuracy	0.10% of 2Mv/V in Comp.
Zero Load Output Shift with Temperature	0.25% F.S./100° F.
Zero Balance	± 1.0% F.S.
Full Scale Output Shift with Temperature	0.25% F.S./100° F.
Compensated Temperature Range	15 - 115° F.
Non Linearity	0.10% F.S. in Compression
Hysteresis	0.02% F.S.
Non-Repeatability	0.02% F.S.
Safe Overload Rating	150% of Rated Capacity
Insulation Resistance	5000 Megohms Bridge to Ground.
	2000 Megohms Cable Shield to Ground

DIMENSIONS

SIZE	A	B	C	D	H	T
3,000# - 10,000#	17/64	3.25	1.35	3.75	1-3/4	1-14NS-2B
20,000#	17/32	5.50	2.40	7.00	2	1½-12NF-2B
25,000# - 50,000#	21/32	6.50	3.00	8.00	2-1/4	2-12UN-2B
75,000# - 100,000#	25/32	8.00	3.60	9.50	2-1/2	2-12UN-2B
200,000# - 250,000#	1-1/32	10.50	4.70	12.50	4	2¾-8UN-2B
300,000# - 500,000#	1-9/32	15.00	7.50	18.00	7-1/2	5-8UN-2B



P.O. BOX 1435 HUNTSVILLE, ALABAMA 35807

225 WYNN DRIVE HUNTSVILLE, ALABAMA 35805

TOROID SERIES 60 CS LOAD CELLS

SPECIFICATIONS

Standard Ranges	500-100,000 Pounds
Bridge Configuration	350 Ohm Single (Options available)
Standard Electrical Connection	10 Feet of Cable
Input Terminal Resistance	350 + 3.5 Ohms
Output Terminal Resistance	350 + 5 Ohms
Recommended Excitation Voltage	10-15 Volts AC or DC
Maximum Excitation Voltage	20 Volts AC or DC
Rated Output	2 MV/Volt Input
Calibration Accuracy	0.10% of 2 MV/V in Comp.
Zero Load Output Shift with Temperature	0.15% F.S./100° F.
Zero Balance	+ 1.0% F.S.
Full Scale Output Shift with Temperature	0.08% F.S./100° F.
Compensated Temperature Range	15° — 115° F.
Non-Linearity	0.05% F.S. in Compression
Hysteresis	0.02% F.S.
Non-Repeatability	0.02% F.S.
Safe Overload Rating	150% of Rated Capacity
Insulation Resistance	5000 Megohms Bridge to Ground, 2000 Megohms Cable Shield to Ground

Specifications Subject to Change Without Notice

DIMENSIONS

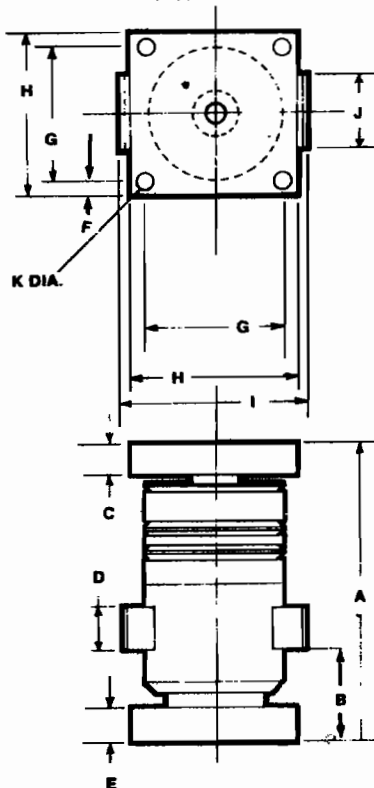

LOAD CELL CAPACITY (LBS) 60C or 60CS
(K = 1,000 LBS)

Dimension (Inches)	.5K-12.5K	15K-30K	35K-70K	75K-100K
A	7.75	10.50	12.00	14.94
B	2.28	3.22	4.72	5.69
C	0.94	1.19	1.19	1.88
D	1.50	1.50	1.50	1.50
E	1.00	1.25	1.25	1.50
F	0.50	0.50	0.50	1.00
G	4.00	5.00	5.00	6.00
H	5.00	6.00	6.00	8.00
I	5.63	7.00	7.00	8.50
J	2.63	2.63	2.63	2.63
K	0.44	0.56	0.56	0.69
Side Travel (60CS only)	±0.150	±0.225	±0.300	±0.375

TOROID

SERIES 60 CS HERMETICALLY SEALED COMPRESSION LOAD CELLS

INTRODUCTION

TOROID has now improved their unique, patented concept in load cell construction - the OMNIFLEX®. The OMNIFLEX load cell has been designed around the proven load cell element which has served industry for many years. It incorporates integral mounting plates and does not require check stays or flexure rods to assure axial loading of the load cell. The improved model, designated Series 60CS, allows for much greater side movement caused by thermal expansion of vessels, agitation, etc. (See capacity and dimension table.) The Series 60CS is more serviceable because of a detachable top plate. This virtually eliminates the possibility of mechanical damage when installing or removing.

NOTE THAT THE MODEL 60CS IS ELECTRICALLY AND MECHANICALLY INTERCHANGEABLE WITH THE EARLIER MODEL 60C. THE ONLY MECHANICAL DIFFERENCE IS THAT MODEL 60CS HAS A DETACHABLE TOP PLATE.

This unique load cell reduces the costs of installation as well as maintenance - two factors often hidden when making capital equipment expenditures. We invite you to compare the cost of installing conventional transducers vs. OMNIFLEX on your next vessel (or other low dynamic loading application). Be sure you consider not only the basic Transducer cost, but also:

- Load cell base and top adaptor plates.
- Design of the stabilizing system.
- Cost of stabilizer AND its associated mounting brackets and hardware.
- Cost of installing the stabilizer system.
- Cost of maintaining the stabilizer system.

SIDE LOAD

With dynamic loading applications such as truck scales or fork lift loaded platforms, stabilizer systems and slider plates are frequently used to protect

the transducers from side loads. But when it comes to tanks, hoppers, and many other material handling applications, OMNIFLEX is your answer. It provides precision weighing accuracy while eliminating the cost and clutter of stabilizers and brackets. The unique construction involving triple diaphragms and an internal ball assures axial loading of the element despite side loads or even eccentric loading up to 4° without appreciable signal deterioration.

INSTALLATION

To optimize the performance of any weighing system (Mechanical, Hydraulic or Strain Gage Transducer), it is important that the load receiver be installed level. Beyond that, with OMNIFLEX it is only necessary that the mounting holes for the base and the top (the hole patterns are identical) be in alignment. There are no external devices required; no awkward projections outside the OMNIFLEX envelope. Again, TOROID invites installation cost comparison.

MAINTENANCE

With the standard load cell, there is the need for check stays or flexure rods as already stated. The OMNIFLEX does not require these devices, lubrication or a preventative maintenance program to keep the load cell performing properly. The assurance of consistent performance is just another reason for the many satisfied OMNIFLEX users.

ORDERING INFORMATION

To order, simply specify SERIES 60CS, the capacity, and the length of the cable. Stainless steel construction, epoxy paint and special construction for hazardous environments are available as options. Call or write your TOROID representative listed on the back of this bulletin, or call us direct. Our Applications Engineers will be happy to review your weighing requirements, or to arrange for our representatives to visit with you.

TOROID SERIES 60 CS LOAD CELL APPLICATIONS

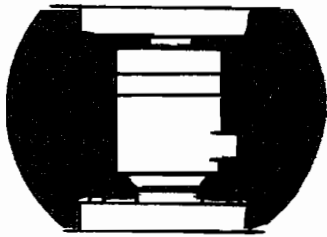

RIGID OMNIFLEX MOUNTINGS

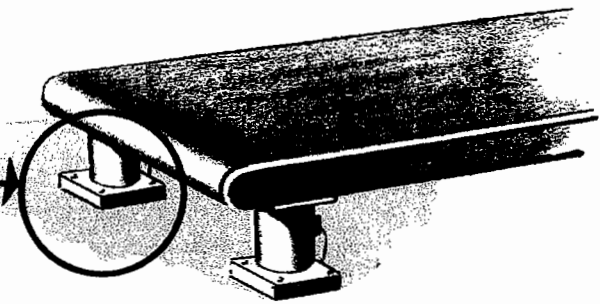

CONVEYOR WEIGH SYSTEM

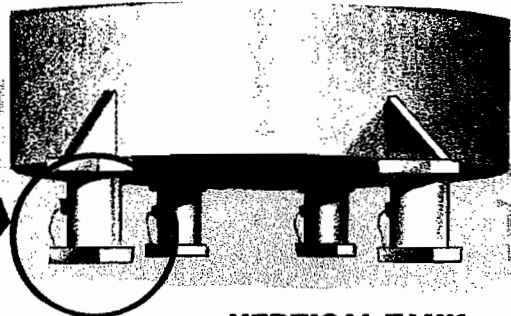

VERTICAL TANK

AND ... with Omniflex...

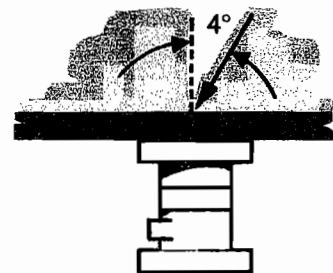
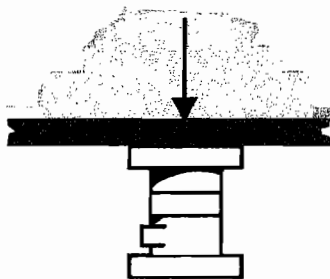
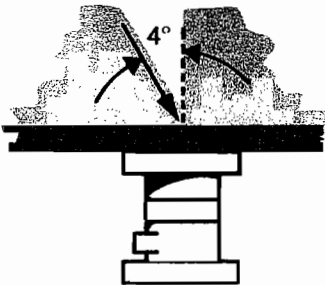

SAME READING / CENTERED OR OFF CENTERED LOADS

Toroid Series 60CS Load Cells provide the "heart" for many industrial weighing applications today. You, too, can be the satisfied owner of a Toroid electronic weighing

system with the Series 60CS Load Cell or one of the many other fine Toroid transducer products. Simply contact your local Toroid representative or call us directly:



Your Local Representative



SERIES 60CS LOAD CELLS APPLICATION INSTRUCTIONS

OMNIFLEX[®] CHARACTERISTICS

TOROID'S proven model 60C OMNIFLEX[®] load cell has now been improved. This patented load cell is furnished including mounting plates, and does not require check stays or flexure rods to assure axial loading of the load cell element. This substantially reduces both installation and maintenance costs. The information below applies to both the 60CS and 60C (except for side travel). When an OMNIFLEX load cell is installed, it becomes a rigid support for the vessel or structure mounted on top of it. It does not need a load button and slider plate to absorb non-axial loads. (Non-axial is defined as a force not coincident to the axial center of the load cell). Therefore, the OMNIFLEX has been constructed so it will physically withstand non-axial forces such as agitator action of the vessel with no loss of accuracy. The new OMNIFLEX model 60CS design allows for much greater side movement caused by thermal expansion and construction of the vessel (see table below).

NOTE:

The 60CS model is even easier to apply than the 60C because of a detachable top plate. This virtually eliminates the possibility of mechanical damage when installing or removing.

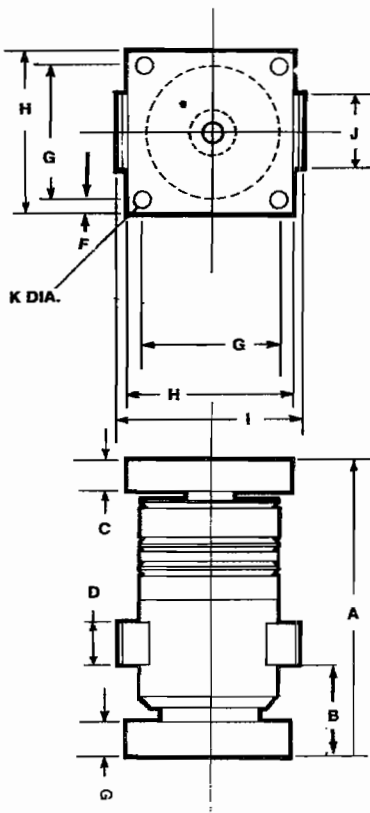

Dimension (Inches)	LOAD CELL CAPACITY (LBS) 60C or 60CS (K = 1,000 LBS)			
	5K-12.5K	15K-30K	35K-70K	75K-100K
A	7.75	10.50	12.00	14.94
B	2.28	3.22	4.72	5.69
C	0.94	1.19	1.19	1.88
D	1.50	1.50	1.50	1.50
E	1.00	1.25	1.25	1.50
F	0.50	0.50	0.50	1.00
G	4.00	5.00	5.00	6.00
H	5.00	6.00	6.00	8.00
I	5.63	7.00	7.00	8.50
J	2.63	2.63	2.63	2.63
K	0.44	0.56	0.56	0.69
Side Travel (60CS only)	±0.150	±0.225	±0.300	±0.375

INSTALLATION CONSIDERATIONS

1. If the top plate is not attached, it should be slipped over the pin, insuring that the rubber sleeve is in place holding the assembly centered.
CAUTION: Do not lift load cell by top plate.
2. For proper system accuracy, each assembly must be plumb.
3. All plumbing and conduit connections to the tank should be made through flexible couplings.
4. The combined spring rate of all tank attachments must be limited to half of the product of the cell capacity times the number of cells.
5. Each load cell should be protected from direct sunlight.
6. In the case of tanks, care should be exercised in placement of load cells prior to tank positioning. The foundation ground to which the cells are fastened - whether concrete or structure - must be level and flat. The load cells, with the top plate on the pin, should be placed on the mounting surface with the bottom plate bolts loosely in place. The weighing structure can then be lowered **CAREFULLY** onto the load cells. The top plate and bolts may then be inserted loosely. (If holes do not line up, mark the structure, raise it off the cells, and enlarge or elongate the holes in the structure as required.)
7. The weighing structure should be leveled by shimming between the load cells and the structure. Care should be taken to assure that the weighing structure is standing free and that all supporting forces will be exerted axially through the load cells only.
8. The distance between the top plate and bottom plate of a load cell when measured at the four corners should be within 1/32" for 5K to 30K load cells and 1/16" for 35K - 100K load cells.
9. When the installation has been judged satisfactory, the load cell mounting plates may be grouted in place (where applicable) and all mounting bolts tightened.
10. The color code for the four-wire cable is as follows:
BLACK - Minus Input RED - Minus Output
GREEN - Plus Input WHITE - Plus Output
11. Calibrate by using the instructions in your indicator operating manual.

LOAD CELL REMOVAL:

If it is necessary to remove a load cell once installed, the following should be observed:

- a. Remove the top plate bolts of the cell to be removed.
- b. To determine the maximum allowable jacking height, measure the distance to the **NEAREST** adjacent corner and multiply by 0.035. If the weighing structure must be moved higher than allowed, remove the top plate bolts from all load cells and perform a straight lift.
- c. With the weighing structure **SAFELY SECURED**, remove the bottom plate bolts, conduit and electrical connections of the cell to be removed.
- d. Cell may now be removed. **CAUTION: Do not lift by top plate.**

NOTE: All of the above information also applies for the model 60C except that the top plate is not detachable.

The TOROID Series 66 Load Pin is a strain gauge type transducer based on the shear force principle. This bulletin is being issued to illustrate the capability and potential of the load pin — not exact specifications.

The load pin was originally developed for boom cranes. Since that development, it has been used in numerous other appli-

cations requiring pin replacement.

Of course, the load pin can be output to a digital indicator, along with related recording and control equipment.

The unique capability which TOROID offers is in the area of pin design to fit the pin dimensions which is to be replaced. If you have an application, please send it in to allow our people to evaluate.

DIMENSIONS - TYPICAL

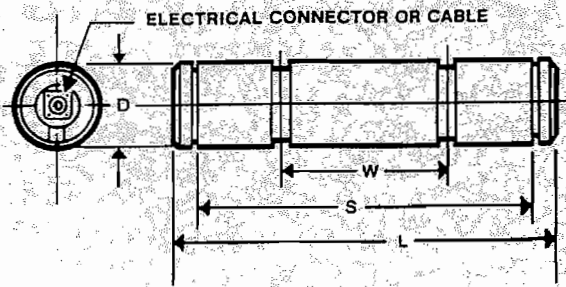

TYPICAL LOAD PIN DIMENSIONS

RATED LOAD	L	S	W	D
35,000	6.00	4.25	2.00	1.75
100,000	10.00	8.00	4.00	3.25
250,000	14.50	13.25	6.00	4.00
500,000	17.60	16.00	8.00	5.75

SPECIFICATIONS

- Capacity: 35,000 Lb. to 500,000 Lb. or any intermediate range
- Full Scale Output: 2 mv/v
- Input Voltage: 15 V AC or DC
- Input Resistance: 350 ohms
- Output Resistance: 350 ohms
- Non-Linearity: .10% F.S.
- Overload. Safe: 125% Rated Output
- Overload. Ultimate: 200% Rated Output
- Sideload. Safe: 125% Rated Output
- Sideload. Ultimate: 200% Rated Output
- Temperature Range: 0°F to -130°F
- Temperature Effects on FS Output: .0008% FS/°F
- on Zero: .0015% FS/°F
- Electrical Termination: As Required

INSTALLATION - TYPICAL

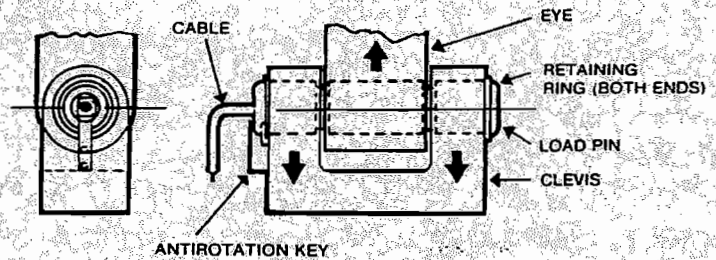

P.O. BOX 1435 HUNTSVILLE, ALABAMA 35807

225 WYNN DRIVE HUNTSVILLE, ALABAMA 35805



**TOROID
CORPORATION**

APPLICATION INSTRUCTIONS

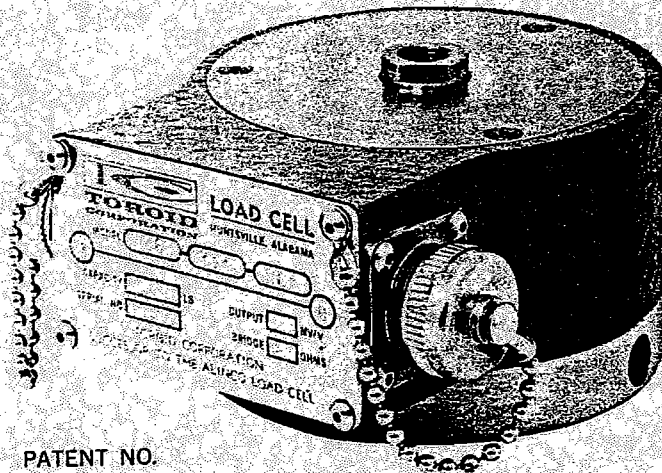

PATENT NO.
3272006

Load Cells **GENERAL INFORMATION**

Toroid load cells are designed for a variety of applications requiring high accuracy and reliability of weight and force measurement. A large number of electrical and mechanical options, as well as special features, are available on Toroid load cells. By the proper selection of features, these cells can be—effect—customer—built to provide maximum accuracy for any given job.

The Toroid load cell is basically a force transducer employing the bonded foil strain gage as the sensing device. An elastic member, located inside a rugged housing, is deformed by an applied force in such a way that the strain produced on its surfaces is proportional to the force applied. Four strain gages, bonded to these surfaces, are connected in a Wheatstone bridge to sense the strain and thus the force

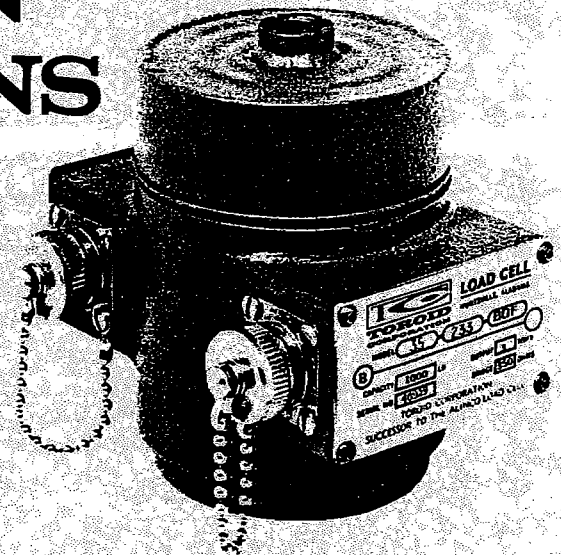

applied. By taking advantage of the unique characteristics of this circuit and the laws of elastic stress distribution, maximum sensitivity to the applied load is obtained. At the same time, sensitivity to undesirable effects such as temperature, torque, bending, etc. is kept to a minimum.

Because eccentric or side loading is nearly always present to some degree, annular flexures are used to minimize the effect on the sensing element. On all Toroid load cells this side load stabilization is designed into the unit. However, care should be taken not to cause side load since this can affect calibration.

Toroid foil strain gages and modulus compensating resistors are bonded to the sensing element and connected in a Wheatstone bridge as shown in Figure 1. In addition, modulus trim, sensitivity trim, balance, balance-compensating and terminal (input resistance adjustment) resistors are placed in a junction box.

There is no standard connector to the Toroid load cell. The connector is specified by our customer and Toroid builds the unit to that requirement. A cable can also be supplied. Refer to the Certificate of Calibration which is packed with the load cell for the exact connection.

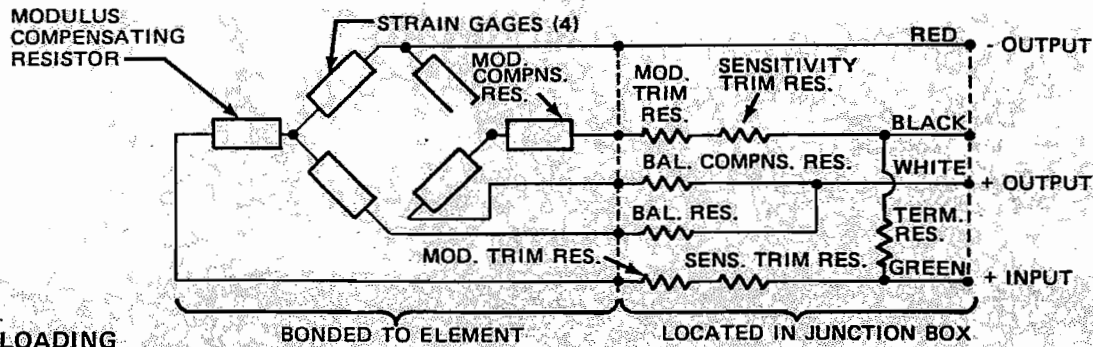

FIGURE 1

LOADING

Two female threads are provided for tension or compressive loadings. When loading in tension, the full length of the threads provided should be engaged, and the load transmitted through the threads. For tension loading in a vertical position, the cell should be used base-up as shown in Figure 2 so as not to weigh itself. It should be provided with flexible connections so that side loads will not be transmitted to the load cell. For compressive loading, the load cell may be set on a flat plate and loaded through a spherical load button. Load buttons should load either through the threads or shoulder on the top of the cell, but should never engage the bottom of the threaded hole in the load cell. Toroid can supply properly designed load buttons for all of its load cells as well as installation assistance.

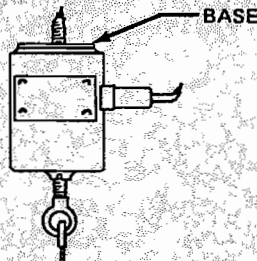

FIGURE 2

Since the load cells measure all vertical forces acting upon the weighing system, it is important that restraining devices or connections (forces other than the vessel, container, contents, etc.) be kept small, elastic and repeatable, so that the effect of these restraining forces can be removed by field calibration.

The actual excitation voltage applied to a load cell can vary considerably due to variations in the inter-connection cable resistance as well variations in the power supply—both ambient temperature changes and drift with time. Since the output of the load cell is directly proportional to the applied voltage, the effect of excitation voltage variations must be nullified. To accomplish this, most highly precision instruments use "sense leads" to connect the load cell excitation input terminals to the instrument. The monitored voltage is used to feed into the instrument as a reference voltage.

OVERLOADS

Toroid load cells are provided with two maximum

overload ratings—200 or 300% F.S. depending upon specific model supplied. (The Series 36 cell has 1000% overload capability) This is the maximum overload that can be safely applied without mechanical damage. Electrical damage or calibration shifts may occur at overloads of 150% F.S.

TEMPERATURE

Toroid load cells are compensated for temperature effects on "no-load" output and sensitivity. The error produced by uniform temperature changes on these parameters is checked at 30 degrees, 75 degrees, and 130 degrees on all standard load cells. The maximum safe exposure temperature is 275 degrees F. At temperatures higher than this, electrical damage can occur. The load cell must be protected from direct solar radiation as well as from other energy sources for maximum accuracy.

Toroid load cells can operate in pressure environments from 0 to 30 psia, but a zero shift will occur. (Except in the case of the Series 36 load cell which is barometrically compensated over this range). The amount of shift will depend upon the pressure and the capacity of the load cell. Special vented cells can be supplied by Toroid to reduce this error to a negligible amount and extend the 30 psia pressure range. These cells are supplied with extra-heavy protective coatings inside to reduce the chance of damage by corrosive liquids or gases.

MOISTURE

Most load cells are hermetically sealed and will withstand all outdoor conditions. The load cells, however, are vulnerable to moisture entering used to terminate the load cell cable in outdoor installation, must be Nema 4 or equivalent in order to protect the cable junction. The load cell cable should also be protected by conduit pipe, where possible.

VIBRATION

Since the load cell has no moving parts, it is ideally suited to withstand vibration. However, the capacity of the load cells, used on installations where vibration is present, must be large enough so that the sum of the vibratory force and the maximum static load will not exceed the safe operating limits of the load cells. Readout instruments used on these installations should be properly filtered.

TOROID / Summing Junction Box

When two or more load cells are summed in an electronic weighing system, there is need for a Toroid Summing Junction Box.

The standard summing junction box is of Nema IV, watertight construction. The unit is available in explosion proof (Nema VII) construction.

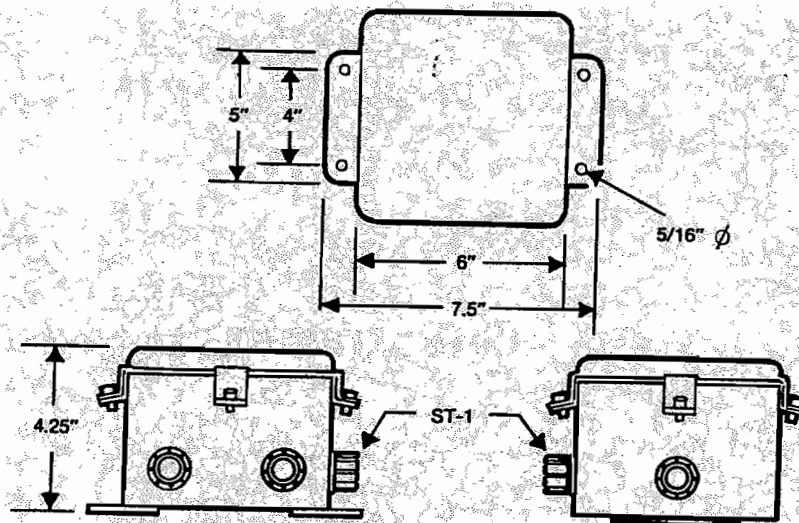

The printed circuit board, within the unit, sums the output of the load cells in parallel. This is a feature used by Toroid to allow a damaged or non-working load cell to be removed without drastically affecting the output of the weighing system.

The Toroid Summing Junction Box is provided with 2, 3, or 4 cell input. The use of this watertight summing box allows the end user and the process to have the assurance of years of continuous service.



P. O. BOX 1435 HUNTSVILLE, ALABAMA 35807

225 WYNN DRIVE HUNTSVILLE, ALABAMA 35805

Toroid

Model

8600

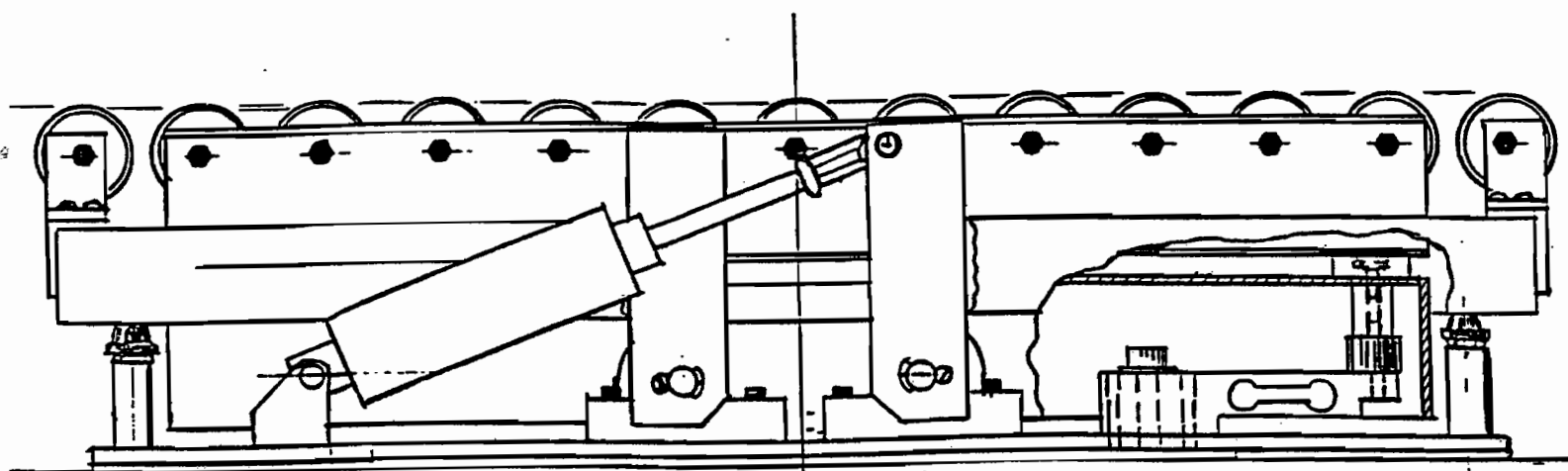

CONTINUOUS WEIGHER

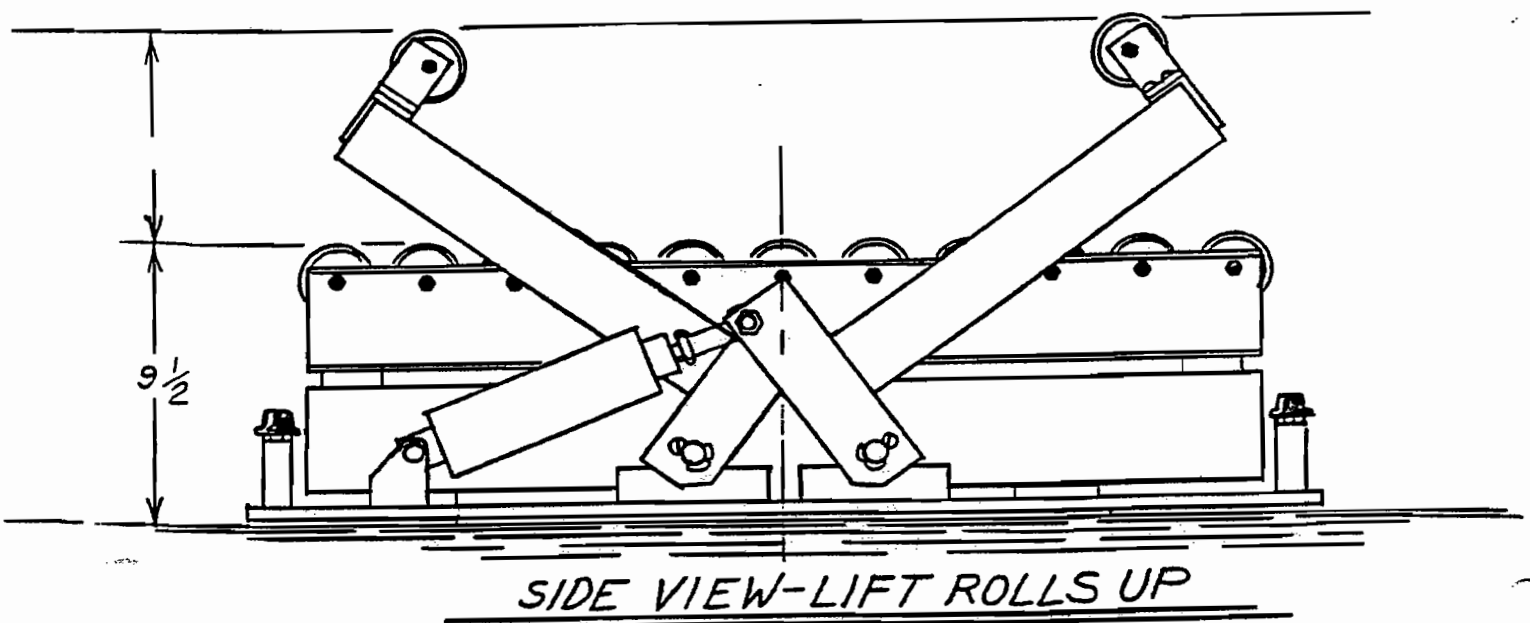
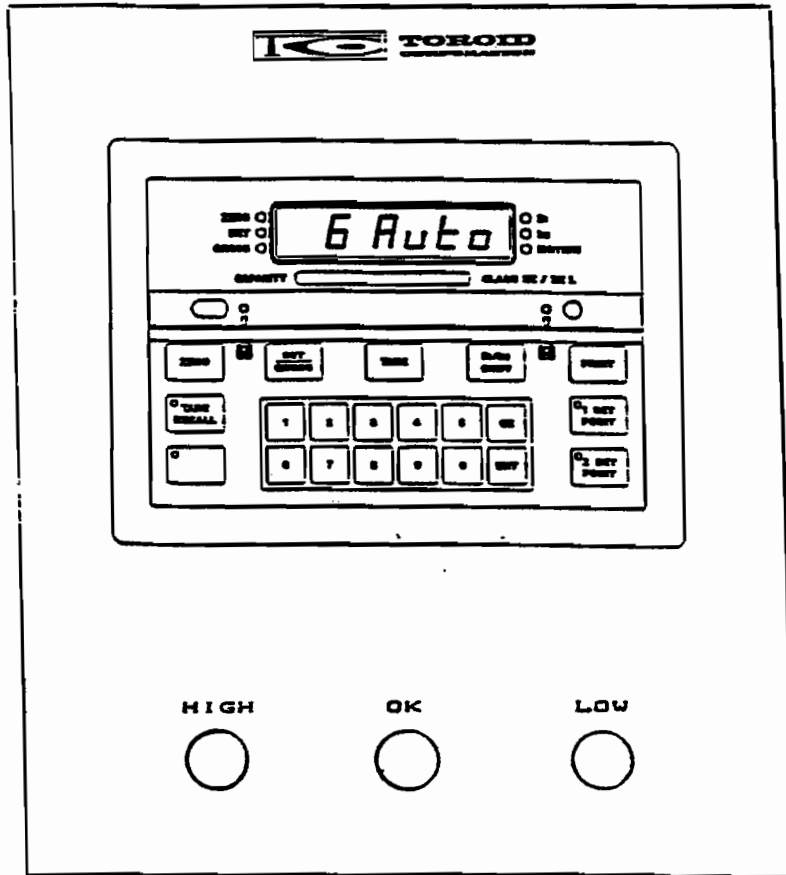

CONTINUOUS WEIGHER

The Toroid Model 8600 Continuous Tread Weigher is a precision electronic scale designed for weighing continuous strip material while in motion. It features digital electronic weighing designed to work continuously for long periods in an abusive factory environment.

PLATFORM SCALE FEATURES

- o 100 pound capacity platform
- o 30 foot power cable.
- o Non-weighing end rollers
- o Factory air-powered lifters to allow the material to continue running while allowing the scale to auto zero.

ELECTRONIC CONTROL FEATURES

- o Digital indicator calibrated to display in pounds per linear foot.
- o Hi low setpoints (to be entered by host computer, or on front panel).
- o Update rate (entered on front panel during configuration).
- o Automatic Zero Maintenance (entered on front panel during configuration).
- o Pilot lights on control panel:

RED	High
GREEN	OK
AMBER	Low
- o R10 relays: 1 each for High, OK, Low indication
- o 0 - 10V Out signal for current gross weight (can be used with chart recorder, etc.).
- o Housed in NEMA 4X stainless steel enclosure 14" X 12" X 6" (deep) for wall mount.
- o Digital calibration
- o 2 set points (High limit/Low limit); can be entered on the control panel or sent to digital indicator via RS232.
- o *EASE OF MAINTENANCE:* In case of Electronic Control failure, Customer can install spare indicator and have the system running in less than one hour.

P.O. BOX 1435 HUNTSVILLE, ALABAMA 35807

225 WYNN DRIVE HUNTSVILLE, ALABAMA 35805

TOROID

Products for the metal industry

The TOROID TEAM has developed a complete line of weighing and force measurement equipment around it's strain gauge load cells and digital instrumentation for the Primary Metals Industry. This equipment, though quite standard, has the capability to be custom applied to the Metals Industry.

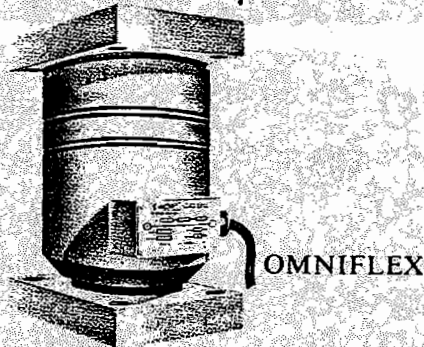

TOROID'S Omniflex® Load Cell has revolutionized the weighing industry due to its unique capability of requiring neither stay nor flexure rods. This device is used on hopper and tank applications up to 50,000# per load cell. The Omniflex®, along with the remainder of TOROID'S load cell line, provides the "heart" of each weighing system. See Bulletins CS1-1001, CS1-1002, CS1-003, CS1-006.

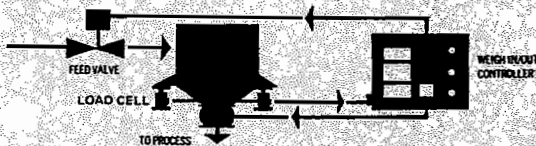

TYPICAL PROCESS CONTROL - BY WEIGHT

The TORIOD TEAM has developed a custom line of rugged full load cell platform weighing systems that are being utilized in the steel industry today. High impact loading, plus 24 hours per day, 7 days a week, reliability are built into these units. The capability moves from existing scale conversion systems to 1 million pound platforms beneath slag pots, larry cars and shipping platforms.

In-Process control by weight is necessary in the Primary Metals Industry and this challenge has been met by TOROID. The simple weight output only on scrap charging scales to total process control for batching, monitoring rate and recording weight have been supplied by TOROID. The combination of strain gauge load cells and digital indicators/controllers have been the key in this success story.

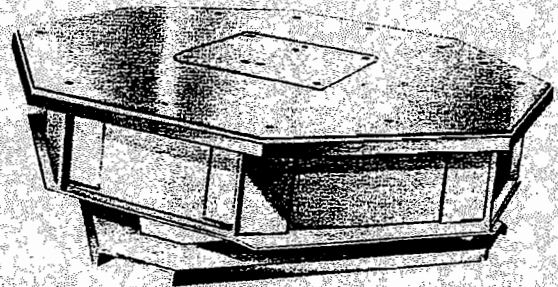

TOROID SLAG WEIGHING PLATFORM

Primary Metals rolling mill stands have provided TOROID with the challenge, as well as the credibility to present it's line of roll force measuring equipment. Major metal suppliers have utilized TOROID'S unique design and custom supplied roll force transducers to provide accurate and reliable data back to their mill computer. TOROID has provided replacement cells for foreign suppliers, as well as new installations. Units range to over 5,000,000 pounds and are complete with solid state instrumentation.

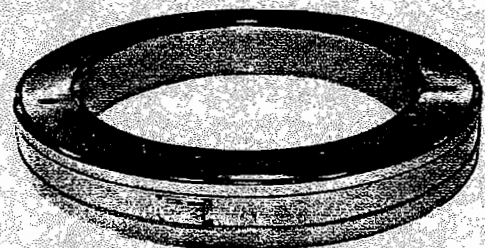

TOROID SERIES 72 RING CELL

P.O. BOX 1435 HUNTSVILLE, ALABAMA 35807

225 WYNN DRIVE HUNTSVILLE, ALABAMA 35805

TOROID / Safety Crane Hook Assembly

The TOROID Crane Hook Assembly has been designed to use with industrial cranes subject to the OSHA standards. The load cell is coupled with a crane hook and eye in the total assembly. The strain gauge load cell provides a signal, through the cable attached to it, to the indicator mounted in the crane cab.

Full scale output is 2 mv/volt and is available in capacities from 1000 lbs. to 100,000 lbs. A fail safe feature provides maximum overload protection to 500% of hook capacity.

TOROID will supply the load cell by itself or the complete hook and eye assembly.

MECHANICAL CONFIGURATION

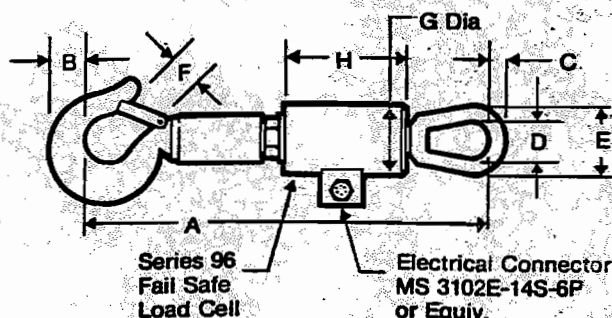

SPECIFICATION

CAPACITY	APPROX. WEIGHT	A	B	C	D	E	F	G	H
1K	11	13.8	1.00	.5	1.5	2.5	.9	3.0	4.5
2K	15	14.5	1.00	.6	1.8	3.0	1.0	3.0	4.5
5K	20	18.0	1.38	.8	2.3	4.0	1.3	3.5	6.0
10K	30	21.5	1.70	1.0	2.5	4.5	1.7	3.5	6.0
20K	75	37.2	3.00	1.2	2.8	5.0	3.0	5.0	8.5
50K	195	45.6	4.56	1.5	4.0	7.0	3.7	6.5	11.4
100K	350	55.3	5.06	2.2	4.3	8.5	4.2	9.0	17.8



P.O. BOX 1435 HUNTSVILLE, ALABAMA 35807

225 WYNN DRIVE HUNTSVILLE, ALABAMA 35805



P.O. BOX 1435 HUNTSVILLE, ALABAMA 35807

225 WYNN DRIVE HUNTSVILLE, ALABAMA 35805

TOROID Low-Boy Low Profile Platforms

Type P47 - For Washdown Environments

Features:

- Full Load Cell Design
- No Moving Parts
- Low Maintenance
- Low Deck Height (3 1/2 in. Nominal)
- Above Deck Adjustable Leveling Pads
- Optional 4° Checker Plate Approach Ramps Available
- Weld Sealed Load Cells
- No Moisture Traps
- Robust Design for Tough Industrial Applications
- Conservatively Rated for Long Service
- Top Performance With TOROID Peripherals
- Easily Adaptable to Most Other Peripherals
- MS3102E-14S-6P Receptacle With Mating Connector and 20 ft. Cable Standard

Standard Sizes:

30 in. x 30 in. x 3 1/2 in.
36 in. x 36 in. x 3 1/2 in.
48 in. x 48 in. x 3 1/2 in.
48 in. x 72 in. x 3 1/2 in.
60 in. x 60 in. x 3 1/2 in.

Standard Capacities*

1,000 lb @ 1 MV/V
2,000 lb @ 2 MV/V
5,000 lb @ 1.25 MV/V
5,000 lb @ 1.25 MV/V
5,000 lb @ 1.25 MV/V

*Safe Off-Center Distributed Quadrant Loading = 50% of Rated Capacity. Other Sizes and Capacities Available.

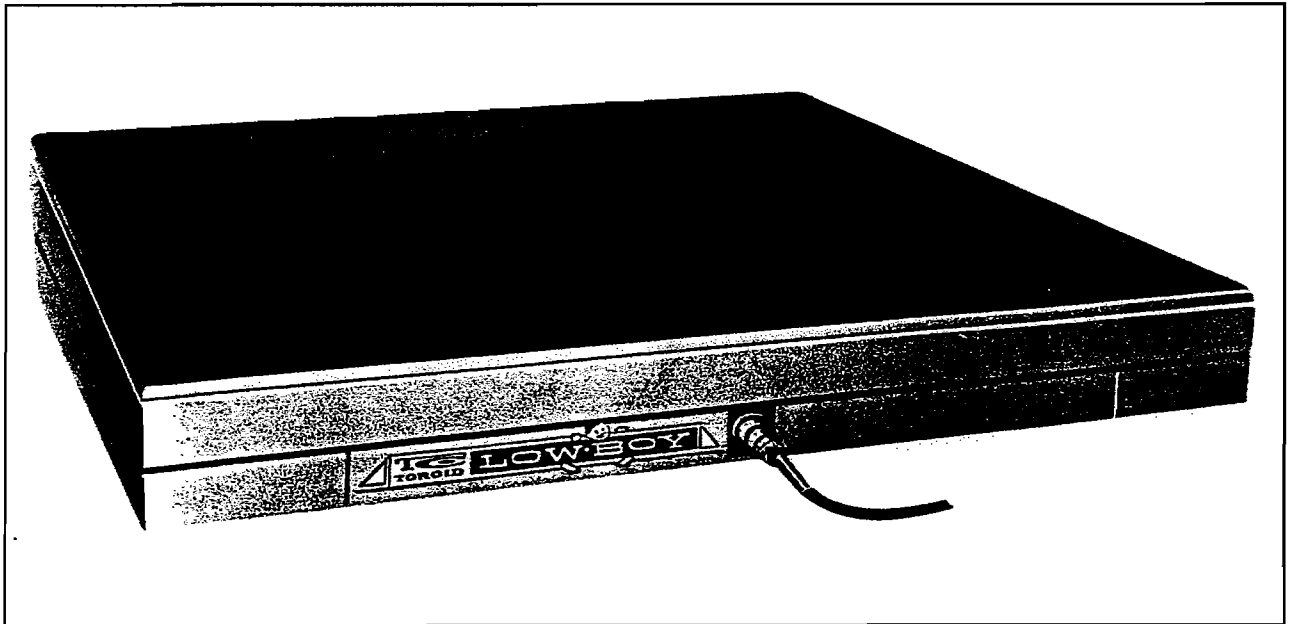



P.O. BOX 1435 HUNTSVILLE, ALABAMA 35807

225 WYNN DRIVE HUNTSVILLE, ALABAMA 35805

TOROID Low-Boy Weigh System Platforms

Type P39S - For Pit Applications

Features:

- High Resolution
- Full Load Cell Design
- Easy Installation
- No Moving Parts
- Low Maintenance
- Fully Assembled at the Factory
- Weld Sealed Load Cells
- Wash Down Capability
- Built in Lifting Eyes and Mounting Lugs
- Conservative Design
- Top Performance With TOROID Peripherals
- Easily Adaptable to Most Other Peripherals

Standard Sizes:

48 in. x 48 in. x 10 in.
48 in. x 72 in. x 10 in.
60 in. x 60 in. x 10 in.
60 in. x 84 in. x 10 in.

Standard Capacities*

5,000 lb @ 1.25 MV/V
10,000 lb @ 1 MV/V
20,000 lb @ 2 MV/V
20,000 lb @ 2 MV/V

*Safe Off-Center Distributed Quadrant Loading = 50% of Rated Capacity. Other Sizes and Capacities Available.

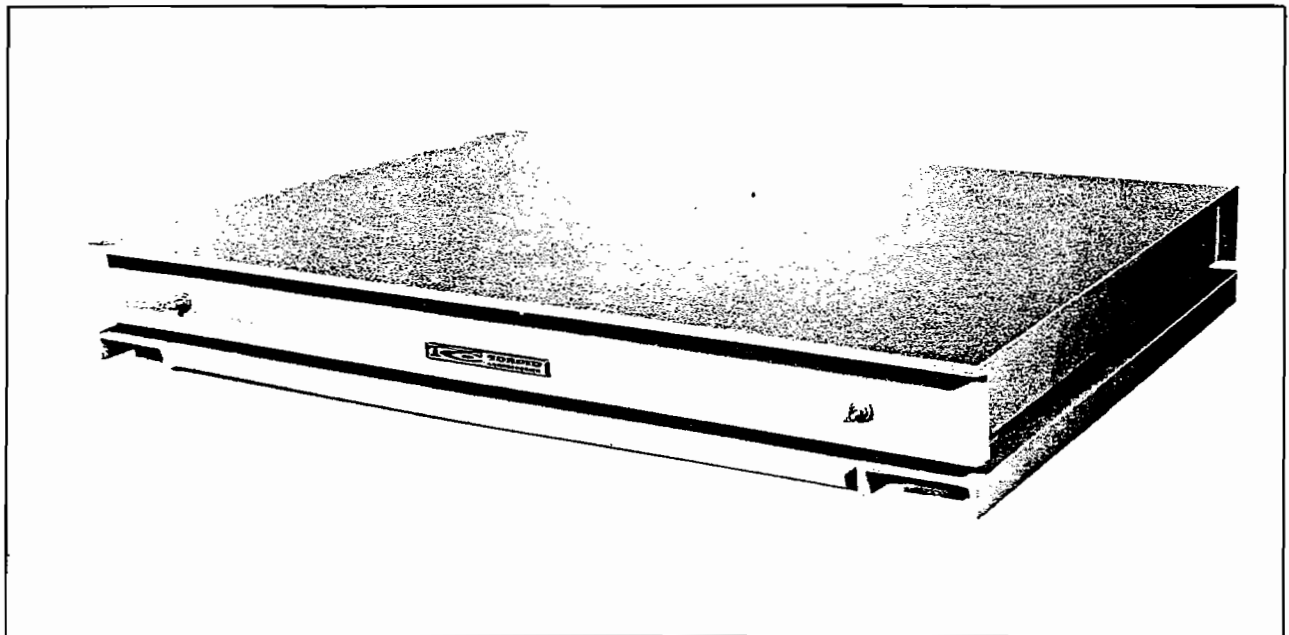



P.O. BOX 1435 HUNTSVILLE, ALABAMA 35807

225 WYNN DRIVE HUNTSVILLE, ALABAMA 35805

TOROID Low-Boy Platforms

Type P39L - For Drive Over Applications

Features:

- No Pit Required
- High Resolution
- Full Load Cell Design
- Checker Plate 4° Approach Ramps and Deck
- No Moving Parts
- Fully Assembled at the Factory
- Weld Sealed Load Cells
- Wash Down Capability
- Built in Lifting Eyes and Mounting Lugs
- Conservative Design
- Top Performance With TOROID Peripherals
- Easily Adaptable to Most Other Peripherals
- MS 3102E-14S-6P Receptacle With Mating Connector and 20 ft. Cable Standard

Standard Deck Sizes:

5 ft x 7 ft
7 ft x 9 ft

Standard Capacities*

10,000 lb @ 1 MV/V
20,000 lb @ 2 MV/V

*Safe Off-Center Distributed Quadrant Loading = 50% Rated Capacity. Other Sizes and Capacities Available.

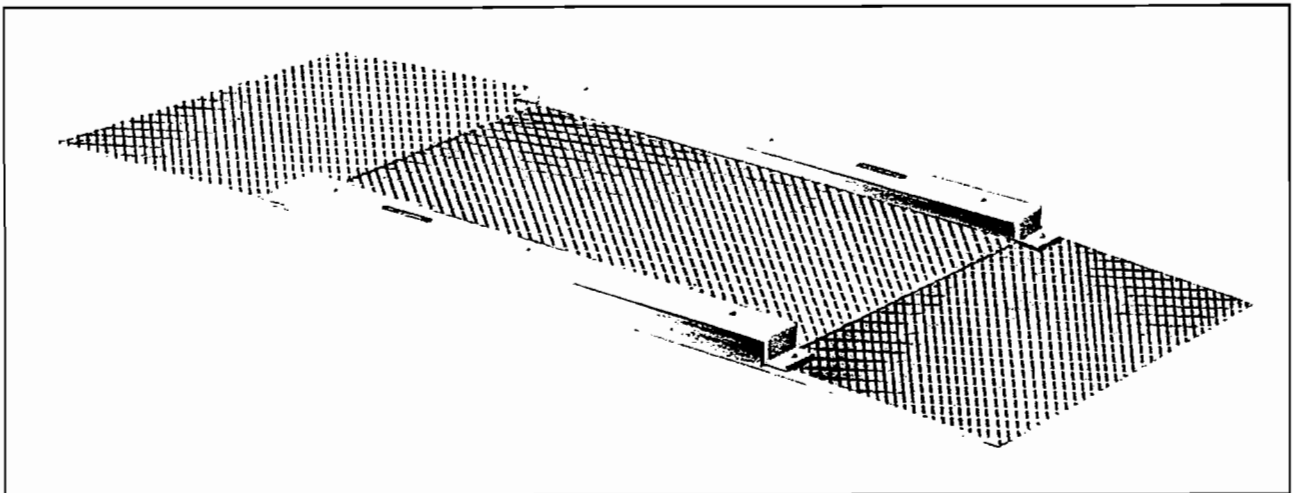



P.O. BOX 1435 HUNTSVILLE, ALABAMA 35807

225 WYNN DRIVE HUNTSVILLE, ALABAMA 35805

TOROID Low-Boy Bench Style Platforms

Type P70 - For Bench/Laboratory Applications

Features:

- High Resolution Capability
- Full Load Cell Design
- No Moving Parts
- Low Maintenance
- Full Stainless Steel Skirted Cover to Protect Interior Parts
- Removable Handles on 18 in. x 18 in. and Larger Sizes
- Conservatively Rated for Long Service
- Top Performance With TOROID Peripherals
- Easily Adaptable to Most Other Peripherals
- MS3102E-14S-6P Receptacle With Mating Connector and 20 ft. Cable Standard

Standard Sizes:

12 in. x 12 in. x 3 1/4 in.
18 in. x 18 in. x 3 1/4 in.
24 in. x 24 in. x 3 1/4 in.

Standard Capacities*

100 lb @ 1 MV/V
200 lb @ 2 MV/V
500 lb @ 1.25 MV/V

*Safe Off-Center Distributed Quadrant Loading = 50% of Rated Capacity. Other Sizes and Capacities Available.

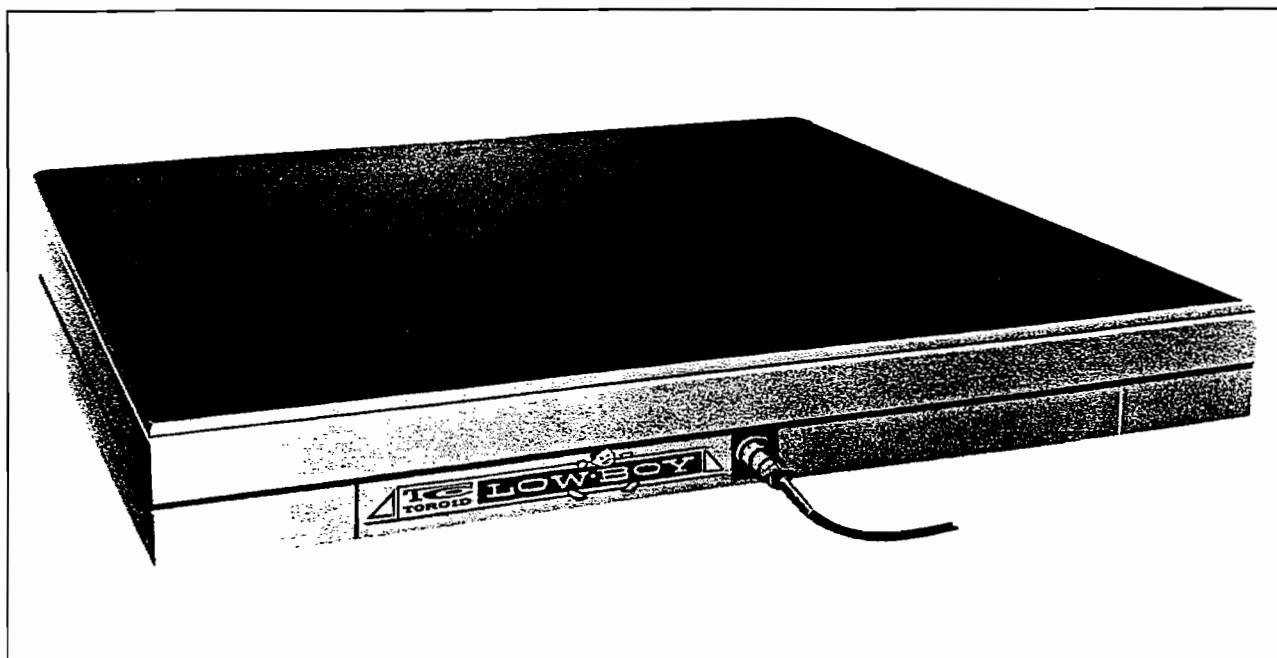



P.O. BOX 1435 HUNTSVILLE, ALABAMA 35807

225 WYNN DRIVE HUNTSVILLE, ALABAMA 35805

TOROID Low-Boy Low Profile Platforms

Type P75 - For Industrial Applications

Features:

- Portable
- Removable Handles Standard
- High Resolution
- Full Load Cell Design
- Structural Steel Fabrication
- No Moving Parts
- Low Maintenance
- Low Deck Height (3 3/4 in.)
- Optional 4^o Checker Plate Approach Ramps Available
- Full Stainless Steel Skirted Covers Available
- Top Performance With TOROID Peripherals
- Easily Adaptable to Other Peripherals
- MS3102E-14S-6P Receptacle With Mating Connector and 20 ft. Cable Standard

Standard Sizes:

24 in. x 24 in. x 3 3/4 in.
30 in. x 30 in. x 3 3/4 in.
36 in. x 36 in. x 3 3/4 in.

Standard Capacities*

500 lb @ 1.25 MV/V
1000 lb @ 1 MV/V
2000 lb @ 2 MV/V

*Safe Off-Center Distributed Quadrant Loading = 50% of Rated Capacity. Other Sizes and Capacities Available.

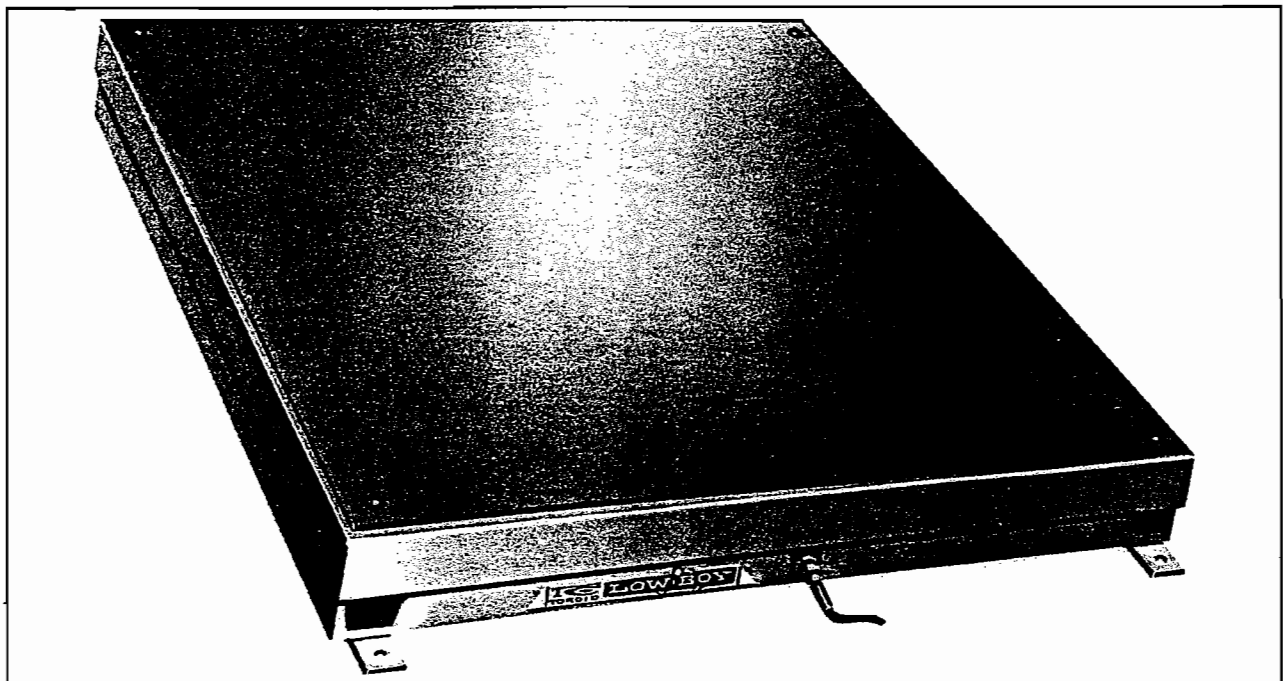



P.O. BOX 1435 HUNTSVILLE, ALABAMA 35807

225 WYNN DRIVE HUNTSVILLE, ALABAMA 35805

TOROID Low-Boy Bench Style Platforms

Type P85- For Bench/Laboratory Applications

Features:

- High Resolution Capability
- Full Load Cell Design
- No Moving Parts
- Low Maintenance
- Full Stainless Steel Skirted Cover to Protect Interior Parts
- Removable Handles on 18 in. x 18 in. and Larger Sizes
- Conservatively Rated for Long Service
- Top Performance With TOROID Peripherals
- Easily Adaptable to Most Other Peripherals
- MS3102E-14S-6P Receptacle With Mating Connector and 20 ft. Cable Standard

Standard Sizes:

12 in. x 12 in. x 3 1/4 in.
18 in. x 18 in. x 3 1/4 in.

Standard Capacities*

100 lb @ 1 MV/V
200 lb @ 2 MV/V

VERSATILITY!
*any industrial
application*

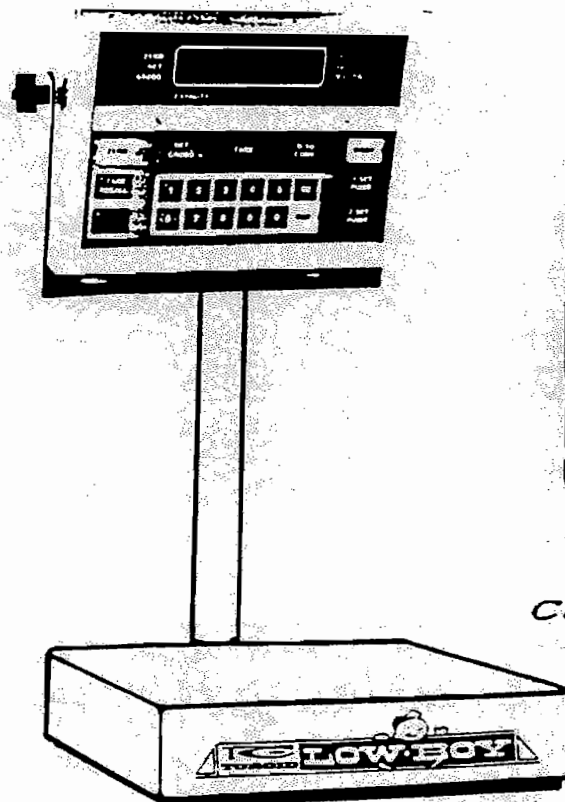

Platform Weighing System

*SINGLE
LOAD CELL
CONSTRUCTION*



omniflex

CS2-3

Force Ranges:

- 1,000 pounds
- 2,500 pounds
- 5,000 pounds
- 10,000 pounds
- 25,000 pounds
- 50,000 pounds
- 75,000 pounds
- 100,000 pounds

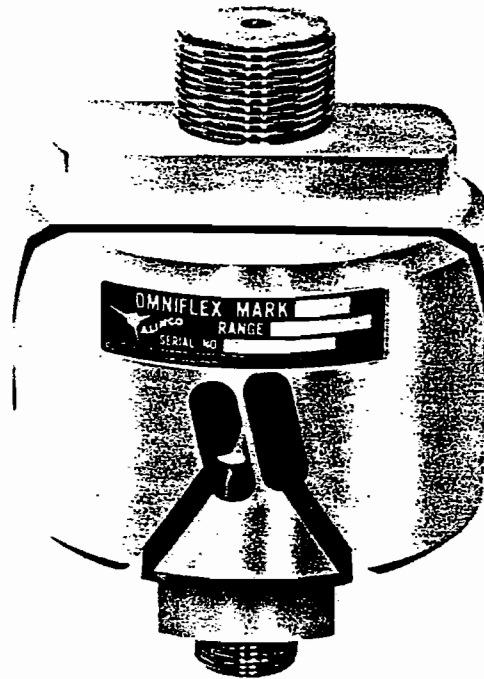

Characteristics:

- 360° universal flexing
- Low restraining moment
- Constant moment at load
- No change in restraint from side or torsional load
- No hysteresis
- High impact strength
- High accuracy

Featuring a completely new and unique arrangement of its four flexure webs, the Mark X Omniflex is specifically designed to afford positive, low-restraint mechanical coupling under high axial loading. This new design permits the Mark X flexure webs to stabilize when subjected to axial, side, or torsional loading - thus, eliminating the need for costly side flexure webs. Additionally, the Mark X provides lower deflection and more uniform loading of flexure webs.

The Mark X is proof tested to 100% of rated capacity, and may be supplied with internal overload pins for added safety. Integral adapters with male and female threads simplify installation and permit use of the unit without additional adapters or special tools.

Because the simplicity of design and construction has decreased production costs, the Mark X Omniflex represents substantial savings to the user with no compromise in precision or reliability.

NOTE: Curves shown on all load vs. angle graphs are for compression loading only. Curves for tension loading are not plotted since they are virtually identical to those shown.

MARK X

Range:
1,000 lbs.

Approx. Safe Side Load (lbs.):
200 lbs.

Approx. Deflection (in./lb.):
 3×10^{-6}

Approx. Torsional Load (in. lb.):
70

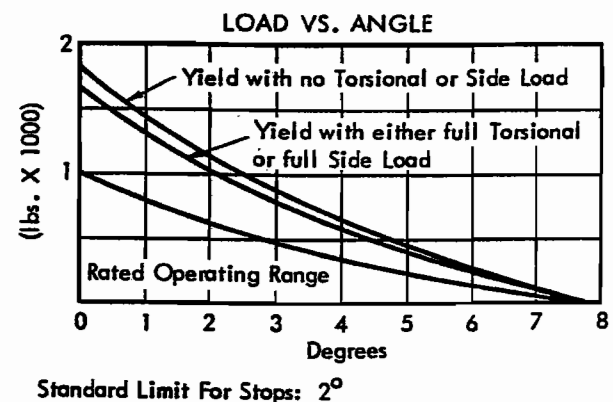
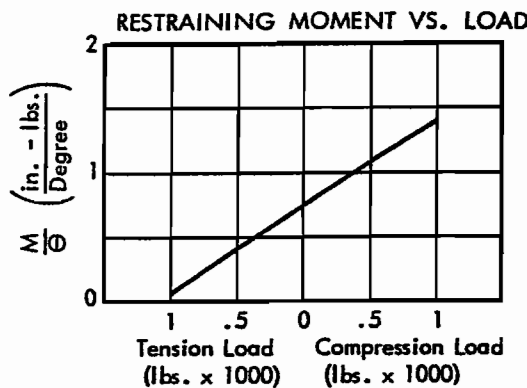

P.O. BOX 1435 HUNTSVILLE, ALABAMA 35807

225 WYNN DRIVE HUNTSVILLE, ALABAMA 35805

MARK X

Range:
2,500 lbs.

Approx. Safe Side
Load (lbs.):
500 lbs.

Approx. Deflection
(in./lb.):
 2×10^{-6}

Approx. Torsional Load
(in. lb.):
300

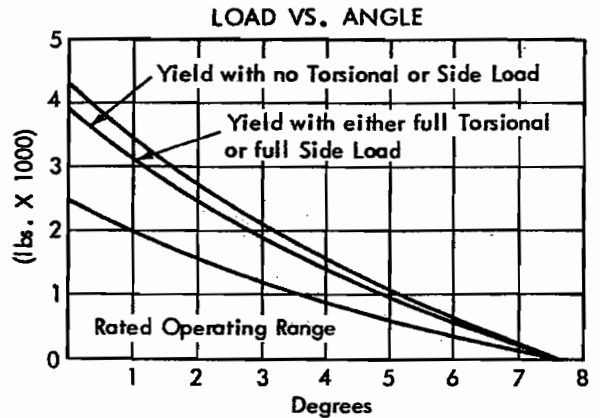
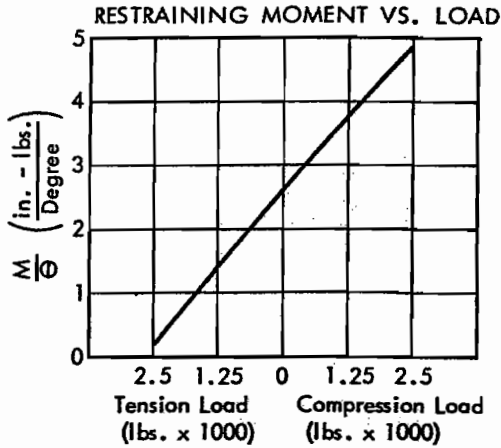

Standard Limit For Stops: 2°

MARK X

Range:
5,000 lbs.

Approx. Safe Side
Load (lbs.):
1,000 lbs.

Approx. Deflection
(in./lb.):
 1.2×10^{-6}

Approx. Torsional Load
(in. lb.):
735

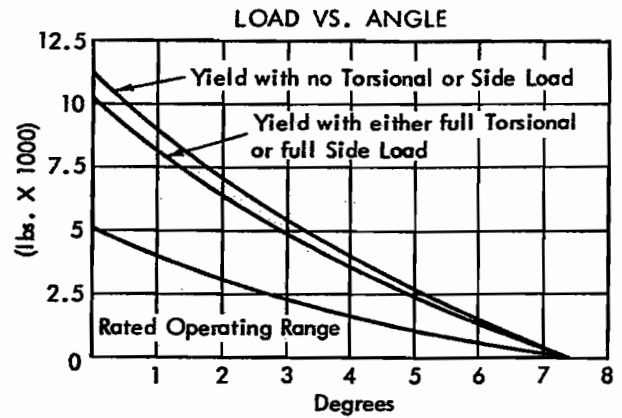
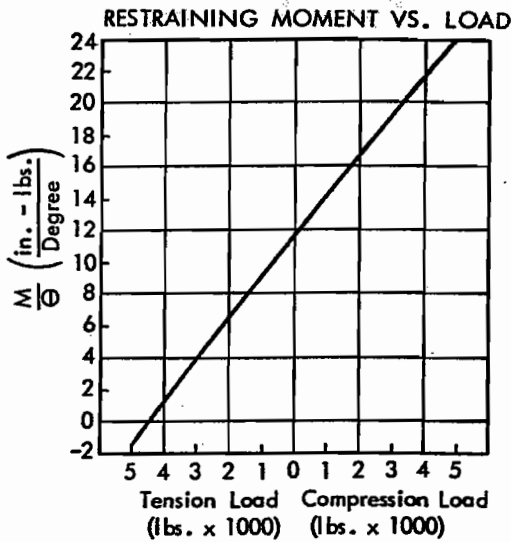

Standard Limit For Stops: 2°

MARK X

Range:
10,000 lbs.

Approx. Safe Side
Load (lbs.):
2,000 lbs.

Approx. Deflection
(in./lb.):
 10×10^{-7}

Approx. Torsional Load
(in. lb.):
1900

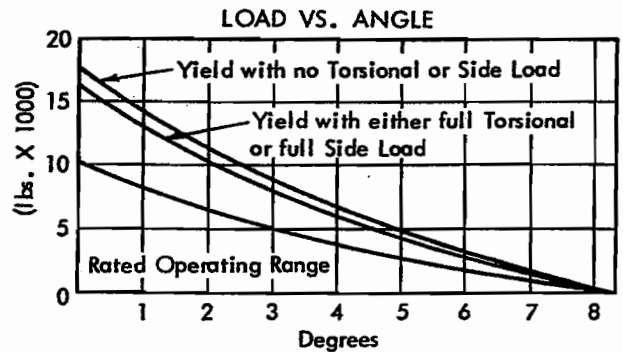
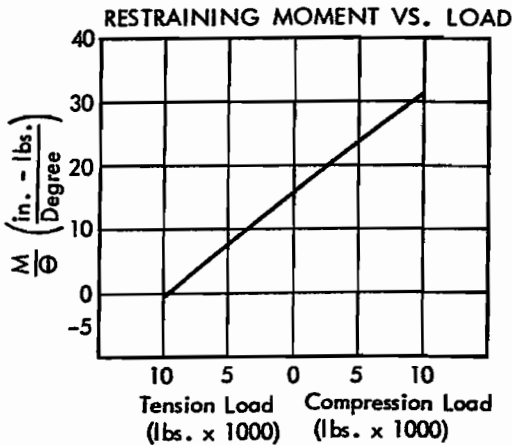

Standard Limit For Stops: 2°

MARK X

Range:
25,000 lbs.

Approx. Safe Side
Load (lbs.):
5,000 lbs.

Approx. Deflection
(in./lb.):
 6×10^{-7}

Approx. Torsional Load
(in. lb.):
6,800

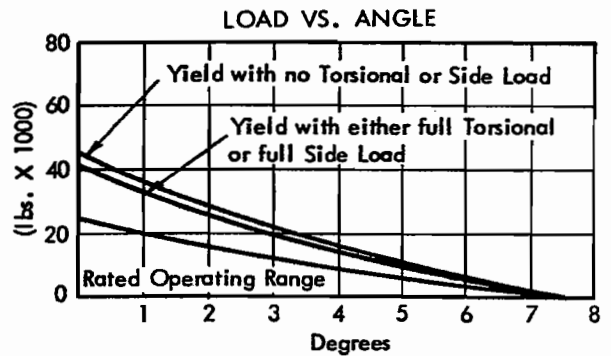
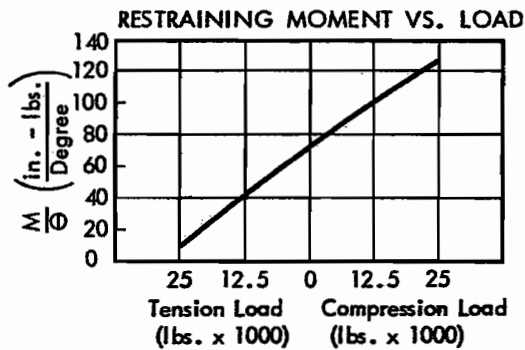

Standard Limit For Stops: 2°

MARK X

Range:
50,000 lbs.

Approx. Safe Side
Load (lbs.):
10,000 lbs.

Approx. Deflection
(in./lb.):
 4×10^{-7}

Approx. Torsional Load
(in. lb.):
22,500

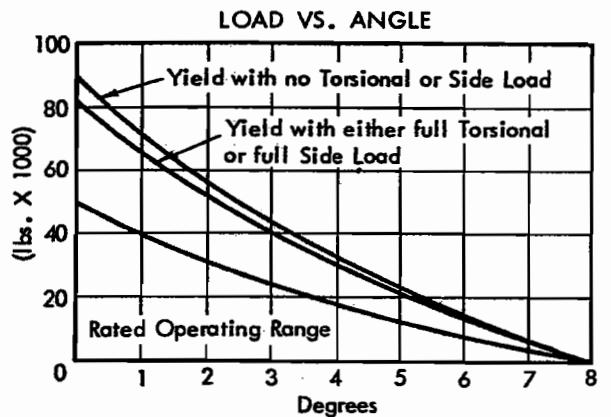
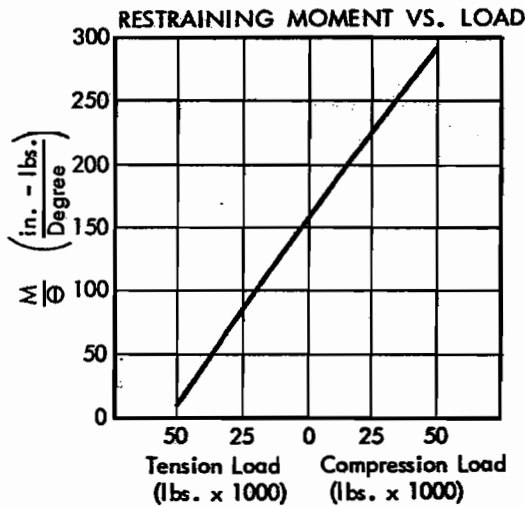

Standard Limit For Stops: 2°

MARK X

Range:
75,000 lbs.

Approx. Safe Side
Load (lbs.):
15,000 lbs.

Approx. Deflection
(in./lb.):
 3.3×10^{-7}

Approx. Torsional Load
(in. lb.):
33,750

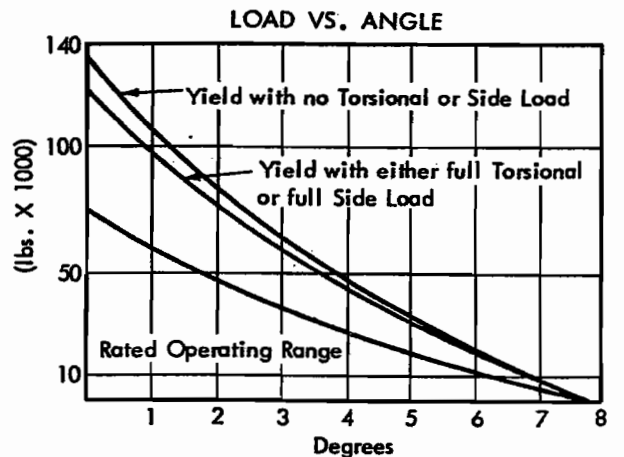
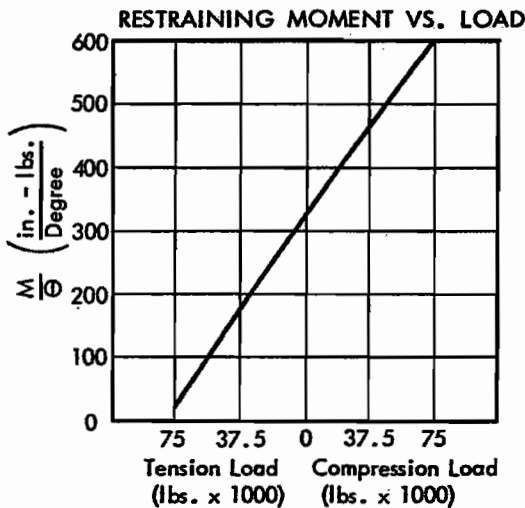

Standard Limit For Stops: 2°

MARK X

Range:
100,000 lbs.

Approx. Safe Side
Load (lbs.):
20,000 lbs.

Approx. Deflection
(in./lb.):
 3×10^{-7}

Approx. Torsional Load
(in. lb.):
50,000

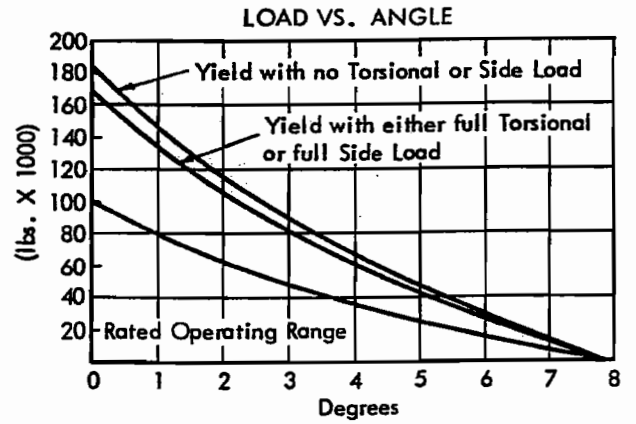
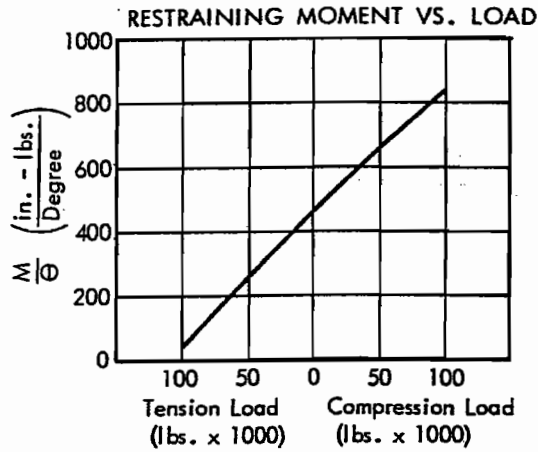

Standard Limit For Stops: 2°

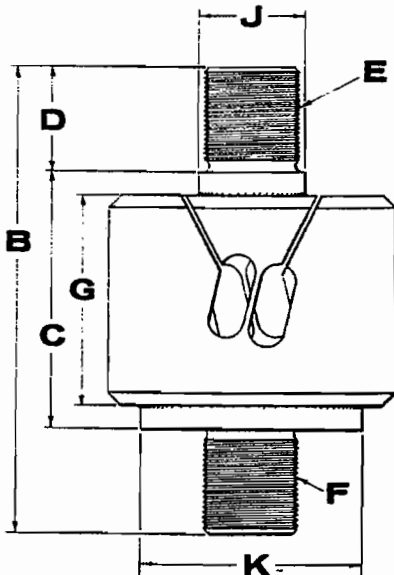
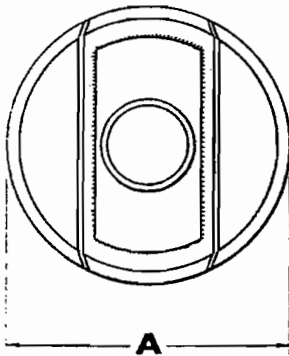

		DIMENSIONS									
		A	B	C	D	E*	F*	G	H	I	K
RANGE	1,000	1.00	3.00	2.00	.50	1/2-20UNF-2A	1/2-20UNF-2A	1.25	.38	.50	3/4
	2,500	1.75	3.25		.50	1/2-20UNF-2A	1/2-20UNF-2A	1.75	.25	.88	1-3/8
	5,000	2.25	3.13	2.25	.44	1/2-20UNF-2A	1/2-20UNF-2A	1.75	.25	1.00	1-7/16
			4.00		.88	3/4-10UNC-2A	3/4-10UNC-2A				
	10,000	3.00	3.88	3.00	.44	1/2-20UNF-2A	1/2-20UNF-2A	2.25	.38	1.12	2-1/4
			4.50		1.13	1-14UNS-2A	1-14UNS-2A				
			4.75		.88	3/4-10UNC-2A	3/4-10UNC-2A				
			5.25		1.13	1-14UNS-2A	1-14UNS-2A				
	25,000	4.50	7.39	5.13	1.13	1-14UNS-2A	1-14UNS-2A	3.13	1.00	1.62	3-3/8
			8.63		1.75	1-1/2-12UNF-2A	1-1/2-12UNF-2A				
	50,000	7.50	9.63	6.00	1.38	1-3/4-5UNC-2A	1-3/4-5UNC-2A	5.00	.50	3.00	5-1/4
			9.50		1.75	1-1/2-12UNF-2A	1-1/2-12UNF-2A				
9.50			1.38		1-3/4-5UNC-2A	1-3/4-5UNC-2A					
75,000	8.00	10.70	7.20	1.75	2-1/4-4ACME-2G	2-1/4-4ACME-2G	5.70	.75	3.00	6-1/2	
		9.96		1.38	1-3/4-5UNC-2A	1-3/4-5UNC-2A					
		10.70		1.75	2-1/4-4ACME-2G	2-1/4-4ACME-2G					
100,000	8.50	11.20	7.20	2.00	2-12UN-2A	2-12UN-2A	6.20	.50	3.00	7	
		11.20		2.00	3-8UN-2A	3-8UN-2A					
		11.20		2.00	3-1/2-4ACME	3-1/2-4ACME					

* Integral split female adapters are available.

P.O. BOX 1435 HUNTSVILLE, ALABAMA 35807

225 WYNN DRIVE HUNTSVILLE, ALABAMA 35805

Force Ranges:

- 500 pounds
- 1,000 pounds
- 5,000 pounds
- 10,000 pounds
- 25,000 pounds

Safety Factor: 2 to 1.



Characteristics:

- Omnidirectional deflection.
- High compliance to rotational loads.
- Constant restraining moment.
- Low axial deflection.
- No adapters needed.

The MARK II OMNIFLEX is particularly useful wherever compliance to deflection in two perpendicular planes or to high-torque rotational loads is required. Precise and reliable measurements under these conditions are made possible through the action of two flexible metal webs placed parallel to the main thrust axis so as to be mutually perpendicular. Such an arrangement provides low restraint and a constant restraining moment regardless of the direction of rotation.

Superior strength and toughness is provided by four sturdy side webs, which easily resist the shock of side and torsional loading, protecting the main thrust webs from over-

loading without imposing significant additional restraint.

Owing to its cylindrical design and the economical internal space requirements of the efficient webs, the MARK II OMNIFLEX is the most compact unit of its kind available today.

One-piece construction completely eliminates slippage, friction, chatter, and wear. Integral studs replace adapters and simplify installation procedures.

Because the MARK II OMNIFLEX is comparatively simple in design and construction, it is low in price when compared to other omnidirectional flexures—though no sacrifice in precision or reliability has been made.

MARK II-5
Range: 500 lb.



Approx. side load: 200 lb.
Approx. deflection: 3.0×10^{-6} in./lb.
Approx. torque load: 60 in./lb.

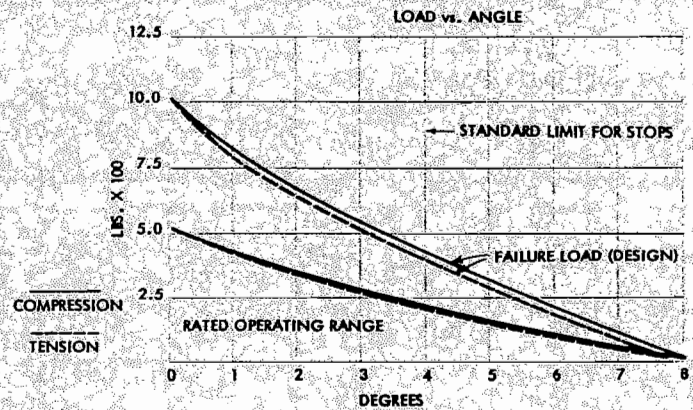
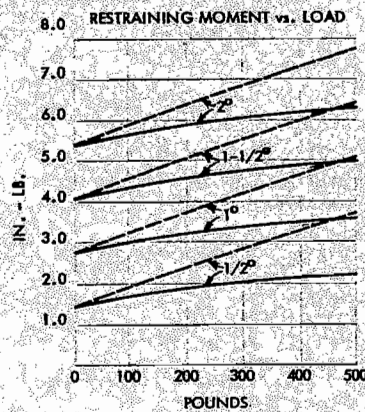

MARK II-1
Range 1000 lb.



Approx. side load: 400 lb.
Approx. deflection: 2.0×10^{-6} in./lb.
Approx. torque load: 120 in./lb.

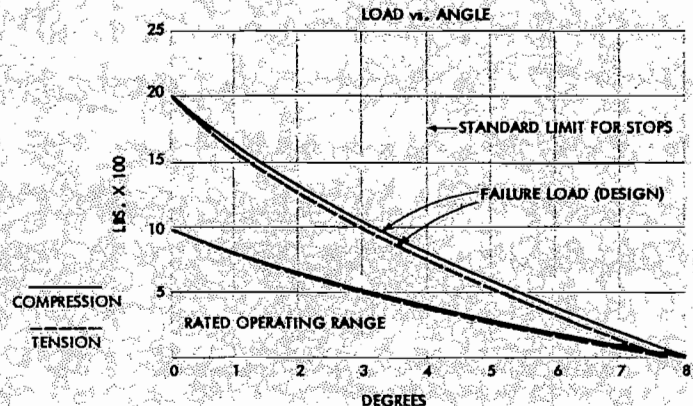
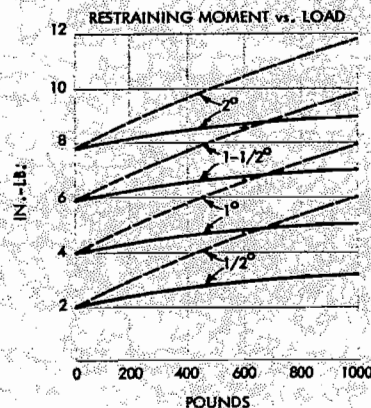

MARK II-5
Range: 5000 lb.

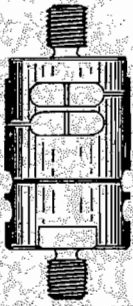

Approx. side load: 1000 lb.
Approx. deflection: 7.0×10^{-7} in/lb.
Approx. torque load: 800 in/lb.

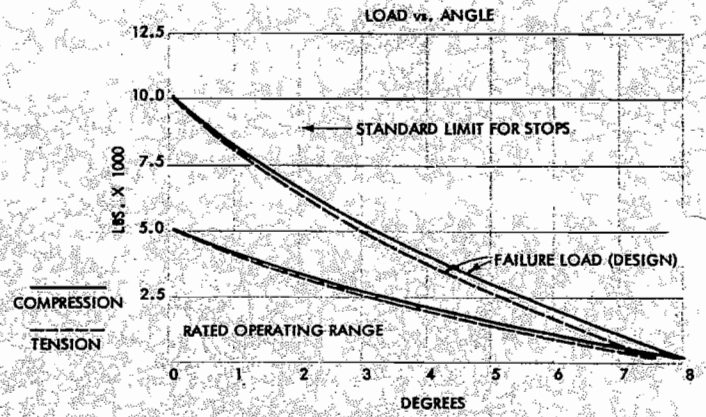
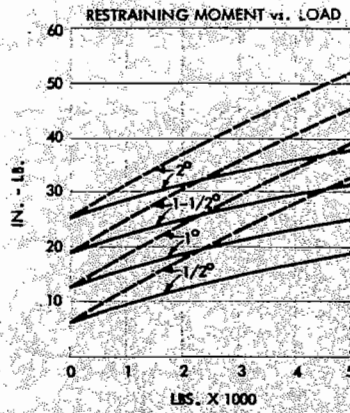

MARK II-10
Range: 10,000 lb.

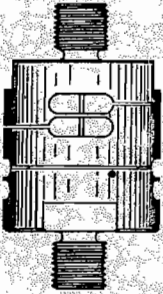

Approx. side load: 2000 lb.
Approx. deflection: 5.0×10^{-7} in/lb.
Approx. torque load: 3400 in/lb.

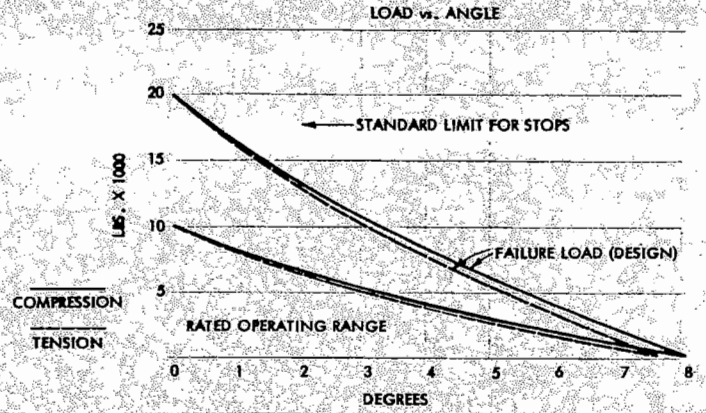
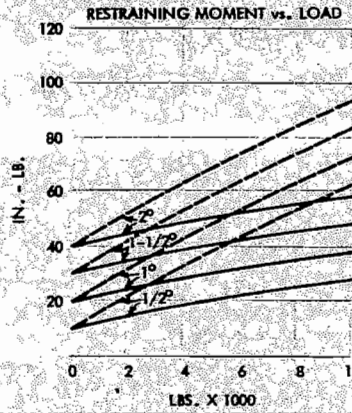

MARK II-25
Range: 25,000 lb.

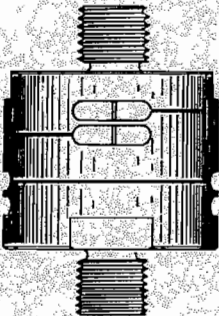

Approx. side load: 5000 lb.
Approx. deflection: 2.5×10^{-7} in/lb.
Approx. torque load: 12,000 in/lb.

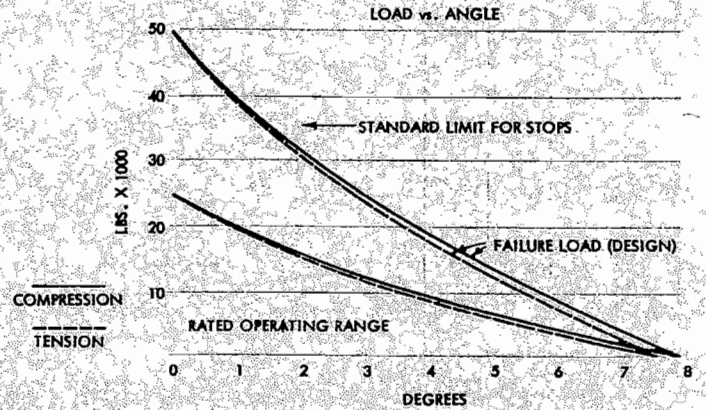
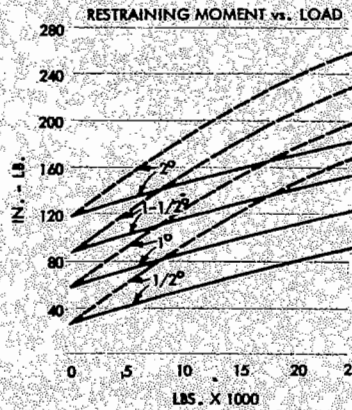

	.5K	1K	5K	10K	25K
A	1.75	1.75	2.75	3.25	4.00
B	.72	.75	1.69	2.63	5.00
C	2.75	2.75	4.00	5.00	7.00
D	.50	.50	.63	.88	1.50
E	.61	.61	1.49	2.25	
F	1/4-28UNF-2A 1/4-28UNF-2A 1/2-20UNF-2A 3/4-10UNC-2A 1/2-12UNF-2A				
G	46	46	78	91	1,15

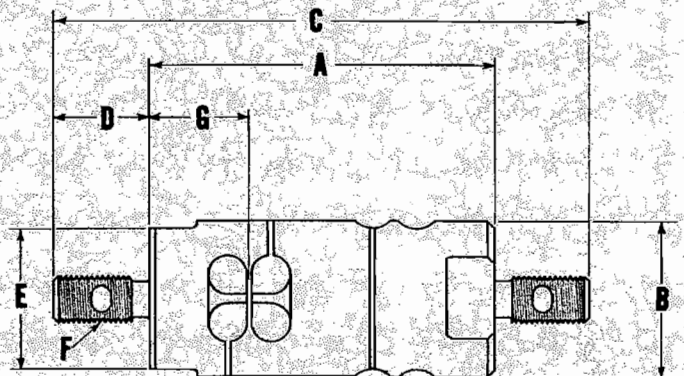

INTRODUCTION

The purpose of this manual is to provide the reader with detail on which to evaluate weighing systems applications. The contents are in a form which will be helpful to anyone who has a weighing application.

Principally, the aim is to allow proper application of strain gage load cells to the weighing and force measurement problems. The success of the installation is credited to proper consideration of the application prior to design.

Toroid's intent is to provide, in a brief form, the concepts of the art of electronic weighing.

TERMINOLOGY AND DEFINITION

Toroid has published a list of terminology and definitions which will be helpful in the understanding of weighing systems. This is included or is available as Form LC-002-006A. This should be read and considered prior to the understanding of the remainder of this manual.

GENERAL INFORMATION

Strain gage load cells have progressed to the point that they can now be applied to most weighing applications and are either equal to or superior to other weight measuring devices; i.e., mechanical scales, hydraulic units, LVDT's, etc.

Some of the more outstanding features of these electronic weighing systems are:

- a. Minimum maintenance-no moving parts and no hydraulic lines.
- b. Low deflection (typically 0.002 to 0.008 inches) permits process piping to be attached to the weighing system.
- c. Weight sensing by hermetically sealed load cells which have rugged steel elements and housings.
- d. Excellent repeatability-- $\pm 0.02\%$ of full scale, or better, under constant environmental conditions.
- e. Accuracy can meet weights and measures requirements. In many cases, better than .05% accuracies of full scale measurement are possible.
- f. Size--can "fit" the application due to the unique shape and small dimensions of the load cell.

It is necessary to follow certain design considerations to obtain maximum performance from electronic weighing systems. The data presented herein is applicable to most weighing applications.

The item to be weighed in an electronic weighing system is supported by one or more load cells. Hermetically sealed within the load cells are sets of matched strain gages bonded to a high-strength, tool-steel, sensing element. The resistance of the strain gages varies in direct proportion to the applied load or force. The resulting variation in output voltage, therefore, is a direct indication of the weight, and is displayed on the readout instrument or control device.

Since the load cells measure all vertical forces acting upon the weighing system, it is important that restraining devices or connections (forces other than the vessel, container, contents, etc.) be kept small, elastic and repeatable, so that the effect of these restraining forces can be removed by field calibration.

The instrument which is used to readout the load cell(s) can be located at the weight sensors or remotely. If mounting the unit remotely, it is suggested that a junction box be utilized to connect the calibrated load cell cable to the extension cable. The cable is then sized to the distance to be run. It is suggested that distances be kept to within 1200' of the weight sensing element. If multiple cells are used, it is normal practice to use a summing junction box at the load cells to maintain the proper signal levels.

The actual excitation voltage applied to a load cell can vary considerably due to variations in the interconnection cable resistance as well as variations in the power supply--both ambient temperature changes and drift with time. Since the output of the load cell is directly proportional to the applied voltage, the effect of excitation voltage variations must be nullified. To accomplish this, most highly precision instruments use "sense leads" to connect the load cell excitation input terminals to the instrument. The monitored voltage is used to feed into the instrument as a reference voltage.

With the above general thoughts in mind, we will now go into some specific information which will be helpful in the application of strain gage load cells.

TOROID APPLICATION MANUAL

LOAD CELL ARRANGEMENT

The structure of the item to be weighed (tank, silo, hopper, platform, etc.) is the governing factor in the arrangement of the load cells. The supporting structure must be evaluated since it will carry the total weight of the item and its contents.

There are many methods in which load cells can be arranged for the performance of the weighing system to be correct. Toroid is not suggesting any specific arrangement due to the fact that each application should be evaluated individually. However, the attached general sketches (WSA 1-11) illustrate some common arrangements for load cell application. These should be used as general guide lines only.

In compression applications, single and double load cell arrangements are used for general weighing where accuracies of $\pm 0.5\%$ or greater are tolerable. Three or more load cells per system must be used in those cases where higher accuracies (.25% of full scale or better) are required, or where structural stability is necessary.

One (1) load cell can be installed in the steelyard of a mechanical scale. This is done by determining the total force which will be applied at the point you will apply the cell under fully loaded conditions. The scale manufacturer's drawings will provide this information or the multiple of the lever system can be determined by measuring pivot distances. The load cell chosen will be a tension unit (in most cases) with appropriate mounting hardware.

General rules for load cell arrangements are as follows:

- a. The supporting structure and/or foundation must be rigid. If more than one tank is to be supported on the same structure, the structure must be designed with sufficient rigidity to prevent errors caused by deflection under varying load conditions.
- b. The tank structure in the area of the load cell mounting must be rigid.
- c. On multiple load cell arrangements the load cells must be positioned and should be installed so that after the weighing system is fully loaded, each cell will carry not more than 100% of its rated capacity.
- d. The members used to maintain the lateral stability of the weigh system must be flexible in the vertical plane and rigid in the horizontal plane. Round members are called rod flexures.
- e. For best weighing results, it is suggested that all plumbing, conduit and other connections to the weighing system be made with flexible couplings.

If flexible couplings are not possible, they all must be evaluated for adequate spring rate. Toroid will calculate this, if necessary. A thumb rule used in this calculation is: The combined spring rate of all connections must be limited to the capacity of the load cell times the number of cells in the weighing system.

- f. Each load cell must be protected from direct solar radiation as well as from other energy sources for maximum system accuracy.

Of course, there are special applications of load cells that will be encountered. Toroid's capable engineering staff is ready to meet that specific need.

Some factors to consider when selecting the load cell(s) will be described in the following paragraphs. These are by no means all inclusive but will provide the reader indication of basic selection criteria.

A. TYPE OF CELL. Load cells are available in compression, tension or both. Compression cells are chosen when the load cell will be mounted below the item to be weighed and above the support structure. Tension cells will be used when the load cell is mounted above the item to be weighed and below the support structure.

B. CAPACITY. The capacity of the load cell(s) to be utilized in a weighing system is determined by the following formula:

$$C = \frac{W_t + W_n}{N}$$

Where: C=Minimum load cell capacity
W_t= Dead Weight
W_n= Net Weight
N= Number of load cells

The dead weight is the weight of the item(s) to be placed onto the load cells prior to applying the product to be weighed. This could be an empty tank for example. This value should also include any additional equipment attached to the item such as agitators, motors, catwalks. These all contribute to the dead weight.

Load cells should be selected with a capacity equal to or greater than the calculated value. In some cases, where the installation is free of shock loads or vibrations, load cells can be used up to 110% of their rated capacity. Refer to Toroid load cell specification sheets where there are many weight ranges. However, load cells of special capacity can be manufactured upon request—a feature of Toroid's capability.

WEIGHING SYSTEMS

C. ACCURACY. The Toroid load cell can be manufactured for most all accuracy requirements up to .05% or better. The load cell should be selected along with the readout instrument to get the total weighing system accuracy. This is generally calculated as the square root of the sum of the squares of all the component accuracies. For example, if you have selected a .07% load cell and a .015% instrument, your weigh system accuracy would be:

$$\text{Combined Accuracy} = \sqrt{(\text{Cell})^2 + (\text{Instrument})^2}$$

$$\text{Combined Accuracy} = \sqrt{(.07)^2 + (.015)^2}$$

$$\text{Combined Accuracy} = .072\%$$

When looking at accuracies, you must review the effect which temperature change has on the accuracy of the equipment. The load cell specification sheets indicate the effect that temperature change has on the load cell accuracy and other related data.

As you look at the total output of the load cell, you see a curve which starts from actual zero and ends at actual full. If you use the entire curve, you have a specific non-linearity attributed to the load cell. However, by using only a portion of the output, you can reduce the non-linearity and increase the accuracy. This is done by proper selection of the load cell and instrumentation. Toroid can be of assistance to you in specific building applications.

D. ENVIRONMENT. Within the environmental consideration of the load cells, there are many areas to consider. Satisfactory performance of a weighing system is dependent upon the ability of the system to function properly while operating under the influence of a wide variety of environmental conditions. The effects of temperature, shock and vibration, wind, rain, snow, ice, corrosive fumes, etc., must be considered when planning a weigh system installation.

Standard load cells are compensated for operation over a temperature range of 30 to 130 degrees F. However, they can be operated over a range of -20 degrees to 275 degrees F without serious problems. High temperature load cells can be operated up to +425°F. Special precautions must be taken, however where load cells will be subjected to temperatures exceeding these limitations. The best method for protecting the cells against temperature extremes can be determined by analyzing the means by which the undesired heat or cold is transferred to the cell (conduction, radiation, etc.)

Temperature changes will cause the vessel or the supporting structure to expand or contract. If the weighing system is not designed to allow for this thermal expansion and contraction, the load cells will be subjected to excessive side-load (horizontal load component) and weighing errors will result. Proper design of the item to be weighed, flexure stay rods, support and load cell placement will reduce the errors caused by temperature change.

As mentioned previously, it is necessary to use some type of stay or rod flexure to assure even loading on the load cell(s). These have been illustrated in various suggested methods on the attached sketches. Some general consideration for these units are as follows:

1. Material to be round stock with a 36,000 psi minimum yield or strength.
2. The rated active deflection is to be equal to or greater than the load cell deflection.
3. Rod flexures do not support the load but keep the cells from being affected by side loads while providing lateral restraint to the weighing system.
4. Rod flexures should be in light tension by torquing equally in pairs.
5. Rod flexures can be used in one or more planes to stabilize the weighing system.
6. The length of rod flexures should all be equal to provide the best weighing performance.
7. Rod flexures must be installed so that they are level when the weigh system is empty.
8. Rod flexure support stands must be designed to take out forces equal to 30% of the capacity of the load cell.
9. The rod flexure should be installed as low as possible on the weighing system and must be below the center of gravity.
10. Load cell and flexure rods must be perpendicular for maximum accuracy.

There are special applications of rod flexures which may be unique but, overall, the above thumbrules will assist you.

WEIGHING APPLICATIONS

WEIGHING SYSTEMS

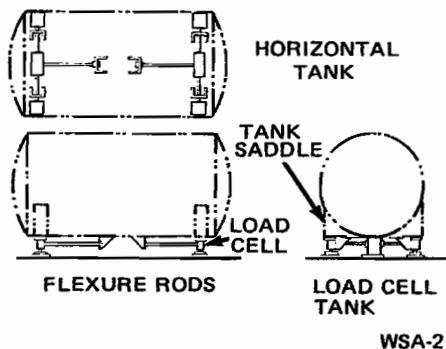
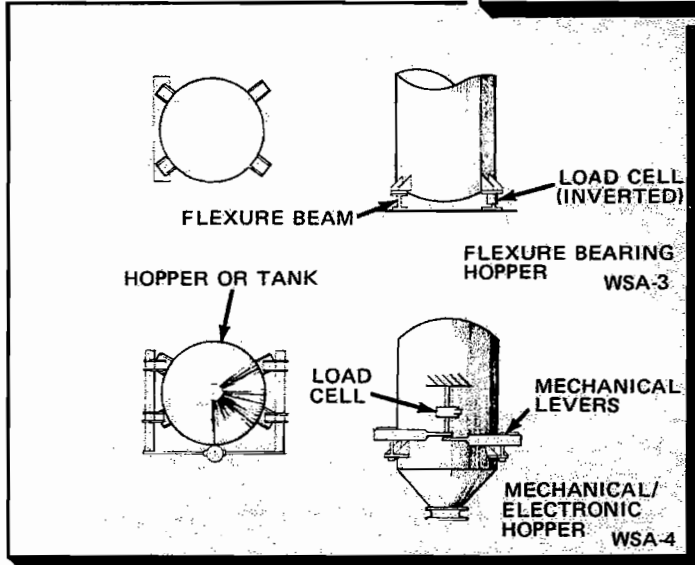
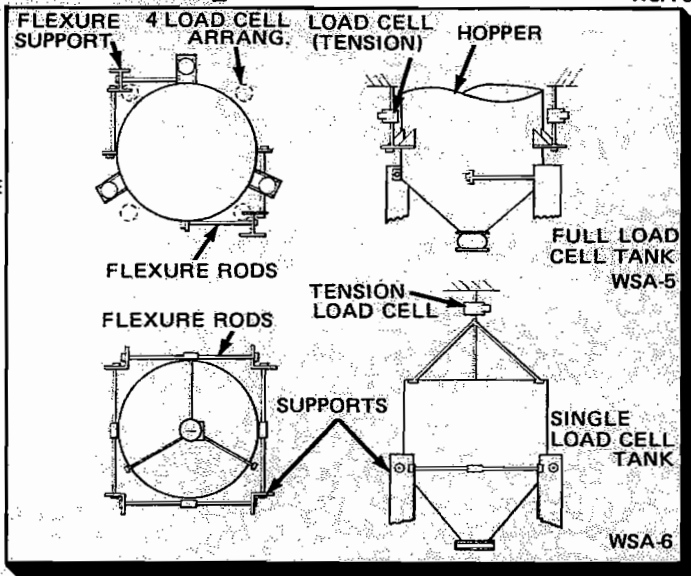
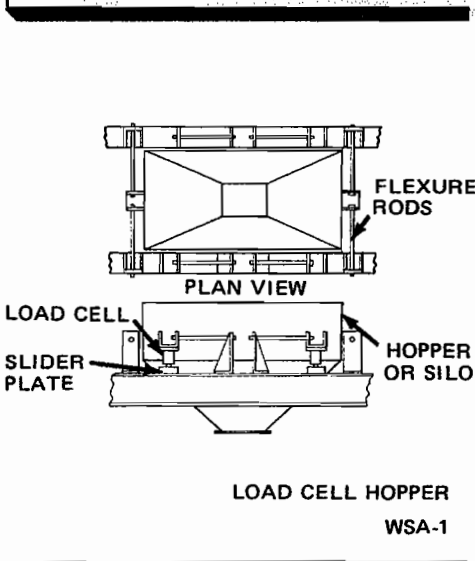
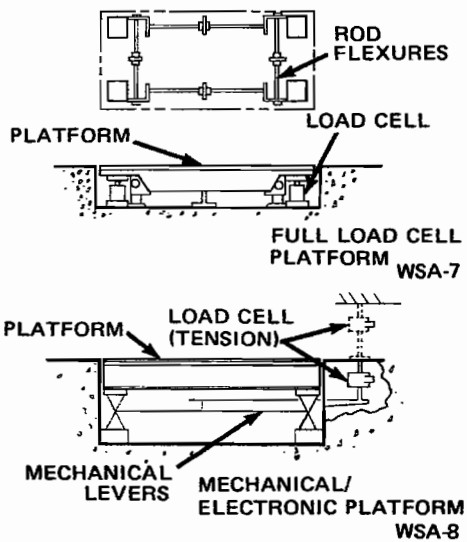
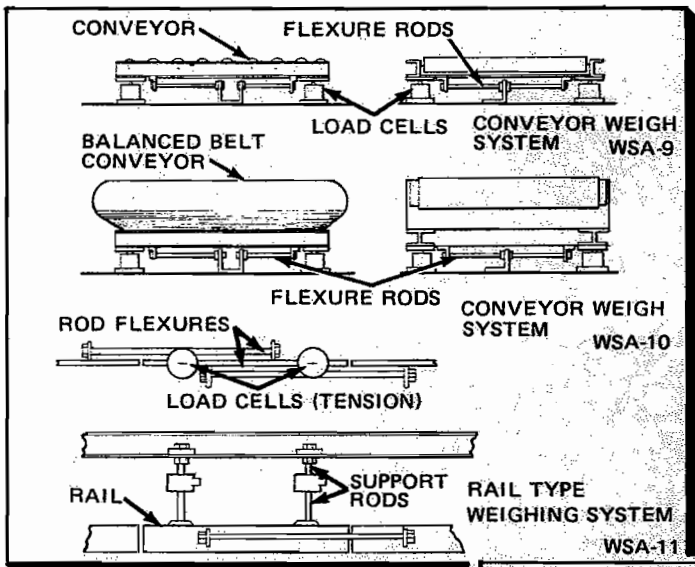



TOROID
CORPORATION

WEIGHING SYSTEMS

Wind acting on a weigh tank, fully supported by load cells and adequately restrained by flexure rods, will have little effect on the accuracy of the system. If a tank or container is mounted high above the ground, large vertical wind components can cause changes in the indicator readings. These changes are easily recognizable and where the frequency of occurrence is low, can be averaged or ignored. Instrumentation reading difficulties caused by prevailing winds can be minimized through the use of a wind screen.

Most load cells are hermetically sealed and will withstand all outdoor conditions. The load cells, however, are vulnerable to moisture entering through the unprotected end of the load cell cable. The junction box, used to terminate the load cell cable in outdoor installation, must be Nema 4 or equivalent in order to protect the cable junction. The load cell cable should also be protected by conduit pipe, where possible.

Since the load cell has no moving parts, it is ideally suited to withstand vibration. However, the capacity of the load cells, used on installations where vibration is present, must be large enough so that the sum of the vibratory force and the maximum static load will not exceed the safe operating limits of the load cells. Readout instruments used on these installations should be properly filtered.

Load cells operating under shock load conditions must also have sufficient capacity to withstand total shock load force as well as the maximum static load. Toroid must review all installations where severe shock loads are anticipated.

The paint on a standard Toroid load cell will resist the corrosive action of mild acids or alkalis. Special protective coatings are required where load cells will be exposed to the corrosive action of harsh chemical agents or compounds. Load cells constructed of corrosion

resistant steel (stainless for example), are also available in most types. Consult Toroid for specific recommendations concerning installations where load cells are to be used in highly corrosive environments.

In the explosion proof applications, it is necessary to understand that the strain gage load cell is a hermetically sealed, low voltage device that is usually classified as intrinsically safe. However, that decision of acceptance has to come from the insurance underwriter on the specific project. It is impossible to modify the cell to make conditions even better than they are, if necessary to satisfy a regulatory agency.

E. INSTRUMENTATION. After the load cells have been selected and applied to the weighing system, the instrument to measure the output of the sensor is chosen. This device can take many forms. The instrument can be: (1) Strip chart recorder; (2) Analog meter; (3) Servo indicator; (4) Electro-mechanical counter; (5) Digital indicator.

Application of the indicator is truly a state of the art. Once the type of readout is decided upon, it is best to send the required information onto Toroid for application and technical calculations.

A weigh system questionnaire developed for the end user by Toroid will assist in this application. The Toroid Weigh System Questionnaire is included herein as reference material or available upon request.

CONCLUSION

This Weighing System Application Manual is intended to be used by those engineering and application personnel involving themselves in load cell applications. Toroid is one of the leaders in load cell systems and hence, this is a document which summarizes some of the philosophy which has placed them in that role of leadership.

This manual is certainly not all inclusive. We trust it has given you additional insight into the load cell weighing area. If additional information is required, Toroid stands ready to serve you.

P.O. BOX 1435
HUNTSVILLE, ALABAMA 35807



225 WYNN DRIVE
HUNTSVILLE, ALABAMA 35805