

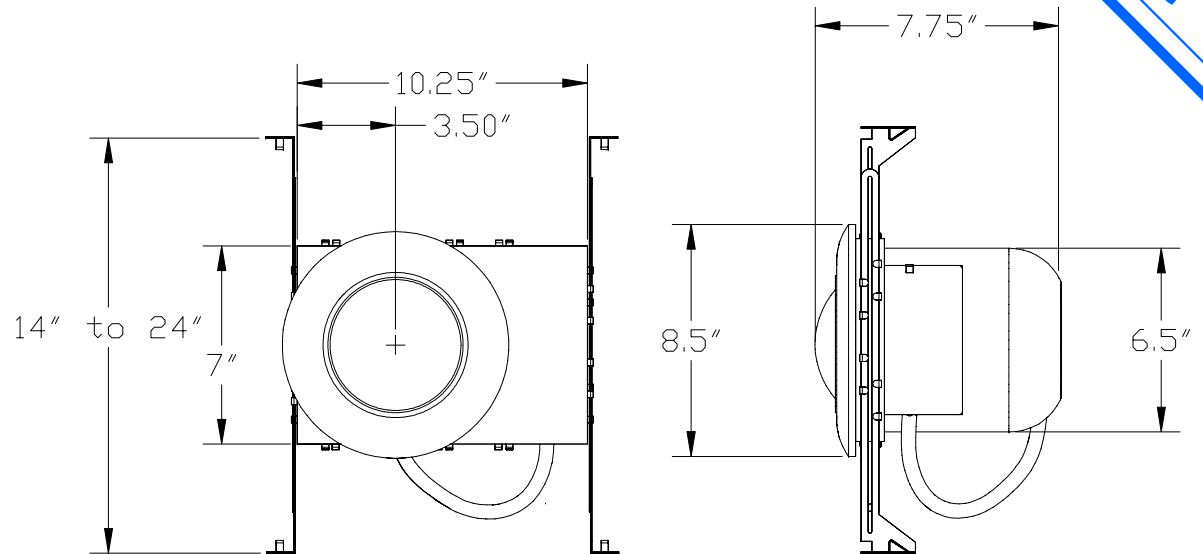

5 Wisconsin Ave.
Norwich, CT 06360
Tel. (860) 887-4550
Fax (860) 887-4534
www.nutron-mfg.com

0286HB Series Recessed Gimbal W/Hanger Bars Emergency Fixture

New Product



Construction: Galvanized Steel Housing, Aluminum Gimbal w/ Galvanized Snap-In wiring box
Standard Gimbal Colors: Powder coated White / Black (Custom colors available consult factory for details)

Electronic Specifications:

Input : 120/277 VAC 60HZ, 8W

Output: 6v 8w Halogen Bi -Pin Lamp for 90 min.

Sealed Maintenance Free Lead Calcium Battery 6V 4AH

24 hour recharge after 90 min discharge

UL listed 924- Multiple Listing Available

Options : Polycarbonate or Glass Lens