

2010

HIGHER SCHOOL CERTIFICATE

TRIAL EXAMINATION

MATHEMATICS EXTENSION 2

General Instructions

- Reading Time – 5 minutes
- Working Time – 3 hours
- Write using blue or black pen
- Board approved calculators may be used
- Write your name on each page
- Each question is to be started in a new booklet.
- This examination paper must NOT be removed from the examination room
- There is a total of eight questions.
- Each question is worth 13 marks.
- Marks may be deducted for careless or badly arranged work.

Question 1 (13 marks) Start a NEW page.**Marks**

(a) Find $\int \frac{\sin \theta}{\cos^5 \theta} d\theta$ 2

(b) Find $\int x e^{2x} dx$ 2

(c) (i) Given that $\frac{4x+20}{(2x-1)(x+6)} = \frac{a}{2x-1} + \frac{b}{x+6}$ find the value of a and b 2

(ii) Hence or otherwise evaluate $\int_2^5 \frac{4x+20}{(2x-1)(x+6)} dx$ 2

(d) Find $\int \frac{4x^3 - 2x^2 + 1}{2x-1} dx$ 3

(e) Find $\int \frac{1}{x^2 + 2x + 5} dx$ 2

Question 2 (13 marks) Start a NEW page.**Marks**

(a) The zeroes of $P(x) = (x-1)(x+i)$ are obviously 1 and $-i$. These are not complex conjugates. How do you explain this? 2

(b) Let $\alpha = -1 + i\sqrt{3}$

(i) Find the exact value of $|\alpha|$ and $\arg(\alpha)$ 2

(ii) Find the exact value of α^7 in the form $a+ib$ where a and b are real. 2

(c) Find the square roots of $-5-12i$ in the form $a+ib$ where a and b are real. 2

(d) The equation $|z-1-3i| + |z-9-3i| = 10$ corresponds to an ellipse in the Argand diagram.

(i) Write down the complex number corresponding to the centre of the ellipse 1

(ii) Sketch the ellipse, and state the lengths of the major and minor axes. 3

(iii) Write down the range of values of $\arg(z)$ for complex numbers z corresponding to points on the ellipse. 1

Question 3 (13 marks) Start a NEW page.

Marks

(a) Given the ellipse $\frac{x^2}{9} + \frac{y^2}{4} = 1$. Find:

- (i) The eccentricity. 2
- (ii) The coordinates of the foci. 1
- (iii) The equation of the directrices. 1

(b) Given the hyperbola $\frac{x^2}{9} - \frac{y^2}{4} = 1$

- (i) Show that the point P with coordinates $(3\sec\theta, 2\tan\theta)$ lies on the hyperbola. 1
- (ii) Find the equation of the normal to the hyperbola at P . 2
- (iii) Find the equations of both asymptotes 1
- (iv) Find the equation of the tangent to the hyperbola at P . 1
- (v) The tangent at P cuts the asymptotes at L and M . Find the coordinates of L and M . 2
- (vi) Show that P is the midpoint of LM . 2

- (a) The graph of $y = f(x)$ is illustrated. The line $y = 0$ is a horizontal asymptote and $x = 5$ is a vertical asymptote.

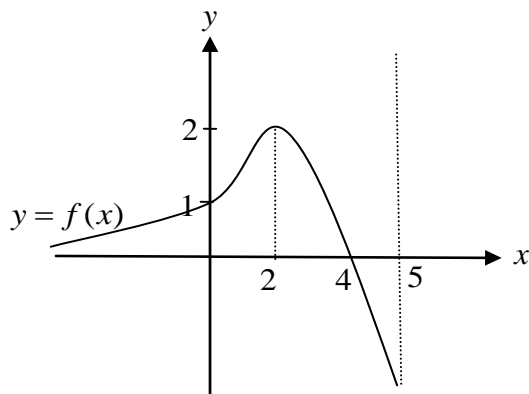

Using the separate page of graphs provided, sketch each of the graphs below. In each case, clearly label any maxima or minima, intercepts and the equations of any asymptotes.

- (i) $y = \frac{1}{f(x)}$ 2
- (ii) $y^2 = f(x)$ 2
- (iii) $y = f(|x|)$ 2
- (iv) $y = [f(x)]^3$ 2
- (b) Consider the function $f(x) = x - \ln(x^2 + 1)$ for $x \geq 0$.
- (i) Show that $f'(x) \geq 0$ for $x \geq 0$. 1
- (ii) Hence deduce that $x > \ln(x^2 + 1)$ for $x > 0$. 1
- (c) Two sides of a triangle are in the ratio 3:1 and the angles opposite these sides differ by $\frac{\pi}{6}$. Show that the smaller of the two angles is $\tan^{-1}\left(\frac{1}{6 - \sqrt{3}}\right)$. 3
- (Hint: let the smaller of the two angles be α)

Question 5 (13 marks) Start a NEW page.

Marks

- (a) Given that if two polynomials $P(x)$ and $Q(x)$ have a common factor of $(x - \alpha)$, then $(x - \alpha)$ is also a factor of $P(x) - Q(x)$.

Hence find the value of k if $x^3 + x^2 - 5x + k = 0$ and $x^3 - 8x^2 + 13x - 2k = 0$ have a common double root. What is the double root?

3

- (b) (i) Find the expansion of $\cos 5\theta$ and $\sin 5\theta$ in terms of powers of $\cos \theta$ and $\sin \theta$.

4

- (ii) Use the results of part (i) to obtain an expression for $\tan 5\theta$ in terms of powers of $\cos \theta$ and $\sin \theta$. Hence prove

$$\tan 5\theta = \frac{5 \tan \theta - 10 \tan^3 \theta + \tan^5 \theta}{1 - 10 \tan^2 \theta + 5 \tan^4 \theta}$$

3

- (iii) Hence solve the equation $t^5 - 5t^4 - 10t^3 + 10t^2 + 5t - 1 = 0$

3

- (a) The diagram shows part of the curve whose parametric equations are given by

$$x = t + 3 \text{ and } y = \frac{20}{\sqrt{t^2 + 16}} .$$

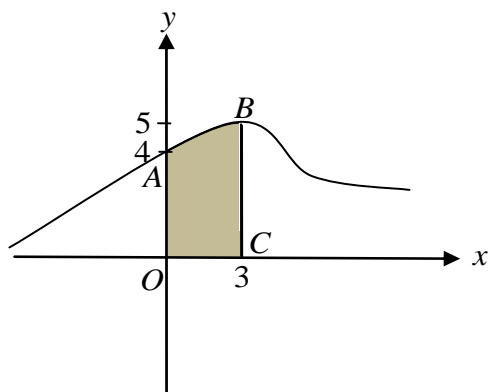

- (i) Find the values of t that correspond to each of the points A and B on the curve. 1
- (ii) A solid is formed by rotating the region $OABC$ about the y -axis. Use the method of cylindrical shells to express the volume in the form 3
- $$V = 40\pi \int_{-3}^0 \frac{t+3}{\sqrt{t^2+16}} dt$$
- (iii) Hence show that the volume of the solid is $40\pi(3\ln(2)-1)$ units³ 3
- (b) The base of a solid is the semi-circular region of radius 1 unit in the x - y plane as illustrated in the diagram below.

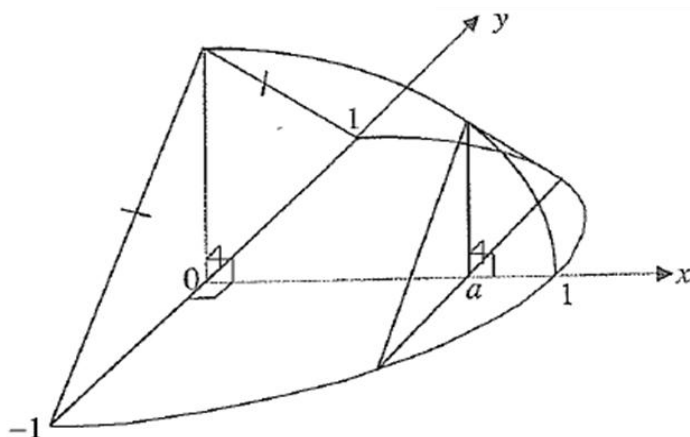

Each cross-section perpendicular to the x -axis is an isosceles triangle with each of the two equal sides three quarters the length of the third side.

- (i) Show that the area of the triangular cross-section at $x = a$ is $\frac{\sqrt{5}}{2}(1-a^2)$ 2
- (ii) Hence find the volume of the solid. 3
- (c) Find the sum of the series $1 + x + x^2 + x^3 + \dots + x^n$ 1

Question 7 (13 marks) Start a NEW page.

Marks

- (a) The points A, B, C and D lie on the circle C_1 . From the exterior point T , a tangent is drawn to point A on C_1 . The line CT passes through D and TC is parallel to AB . Let $\angle ADT = \theta$.

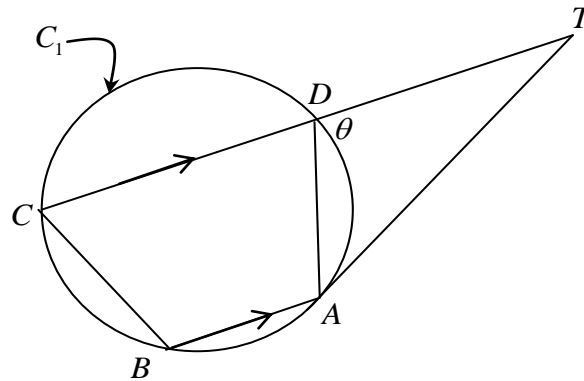

- (i) Use diagram (I) supplied at the end of this paper.
 (ii) Prove that $\triangle ADT$ is similar to $\triangle ABC$.

3

The line BA is produced through A to point M , which lies on a second circle C_2 . The points A, D, T also lie on C_2 and the line DM crosses AT at O .

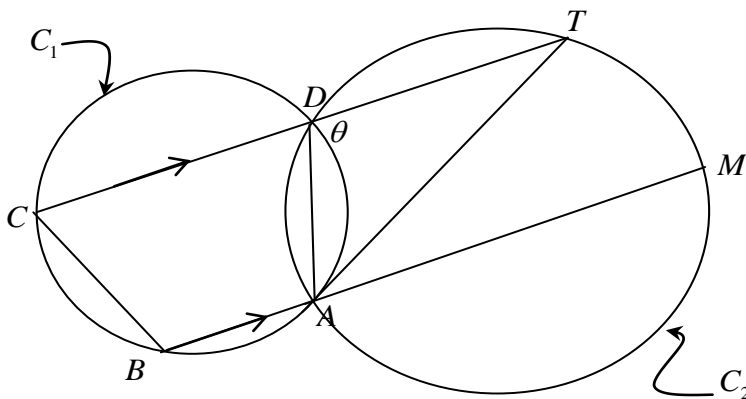

- (iii) Show that $\triangle OMA$ is isosceles. Use diagram (II) supplied at the end of this paper. **2**
 (iv) Show that $TM = BC$. **2**
 (b) Let α, β and γ be the roots of the cubic equation $x^3 - 5x^2 + 13x - 7 = 0$.
 Find the polynomial with roots α^2, β^2 and γ^2 . **2**
 (c) The equation $x^3 - 4x + 5 = 0$ has roots α, β and γ .
 (i) Find the value of $\alpha^3 + \beta^3 + \gamma^3$. **2**
 (ii) Find the value of $(\alpha + \beta)^2 + (\alpha + \gamma)^2 + (\beta + \gamma)^2$. **2**

(a)

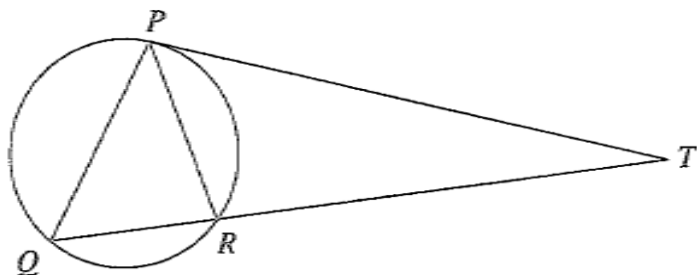

PT is a tangent to the circle PRQ and QR is a secant intersecting the circle in Q and R . The line QR intersects PT at T .

Copy or trace the diagram into your Writing Booklet

(i) Prove that the triangles PRT and QPT are similar 2

(ii) Hence prove that $PT^2 = QT \times RT$ 2

(b)

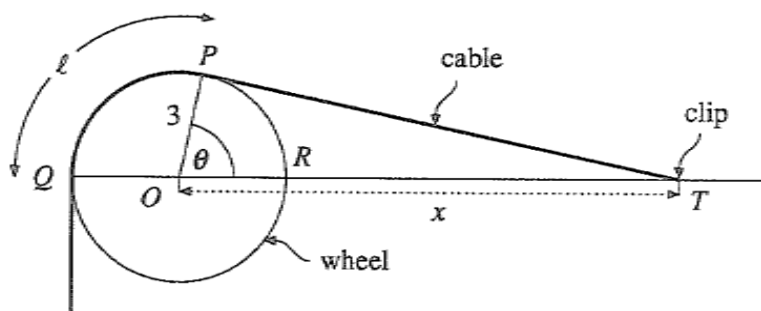

A long cable is wrapped over a wheel of radius 3 metres and one end is attached to a clip at T . The centre of the wheel is at O , and QR is a diameter. The point T lies on the line OR at a distance x metres from O .

The cable is tangential to the wheel at P and Q as shown. Let $\angle POR = \theta$ (in radians).

The length of cable in contact with the wheel is ℓ metres; that is, the length of the arc between P and Q is ℓ metres.

(i) Explain why $\cos \theta = \frac{3}{x}$. 1

(ii) Show that $\ell = 3 \left[\pi - \cos^{-1} \left(\frac{3}{x} \right) \right]$. 2

(iii) Show that $\frac{d\ell}{dx} = \frac{-9}{x\sqrt{x^2 - 9}}$. 2

What is the significance of the fact that $\frac{d\ell}{dx}$ is negative?

(iv) Let $s = \ell + PT$. 2
Using part (a), or otherwise, express s in terms of x .

(v) The clip at T is moved away from O along the line OR at a constant speed of 2 metres per second. 2

Find the rate at which s changes when $x = 10$.

Table of Standard Integrals

$$\int x^n dx = \frac{1}{n+1} x^{n+1}, \quad n \neq -1; \quad x \neq 0, \text{ if } n < 0$$

$$\int \frac{1}{x} dx = \ln x, \quad x > 0$$

$$\int e^{ax} dx = \frac{1}{a} e^{ax}, \quad a \neq 0$$

$$\int \cos ax dx = \frac{1}{a} \sin ax, \quad a \neq 0$$

$$\int \sin ax dx = -\frac{1}{a} \cos ax, \quad a \neq 0$$

$$\int \sec^2 ax dx = \frac{1}{a} \tan ax, \quad a \neq 0$$

$$\int \sec ax \tan ax dx = \frac{1}{a} \sec ax, \quad a \neq 0$$

$$\int \frac{1}{a^2 + x^2} dx = \frac{1}{a} \tan^{-1} \frac{x}{a}, \quad a \neq 0$$

$$\int \frac{1}{\sqrt{a^2 - x^2}} dx = \sin^{-1} \frac{x}{a}, \quad a > 0, \quad -a < x < a$$

$$\int \frac{1}{\sqrt{x^2 - a^2}} dx = \ln \left(x + \sqrt{x^2 - a^2} \right), \quad x > a > 0$$

$$\int \frac{1}{\sqrt{x^2 + a^2}} dx = \ln \left(x + \sqrt{x^2 + a^2} \right)$$

NOTE: $\ln x = \log_e x$, $x > 0$

Question 4: Detach and hand in this page. STUDENT NUMBER.....

Use these sketches for your answers to question 4

(i) $y = \frac{1}{f(x)}$

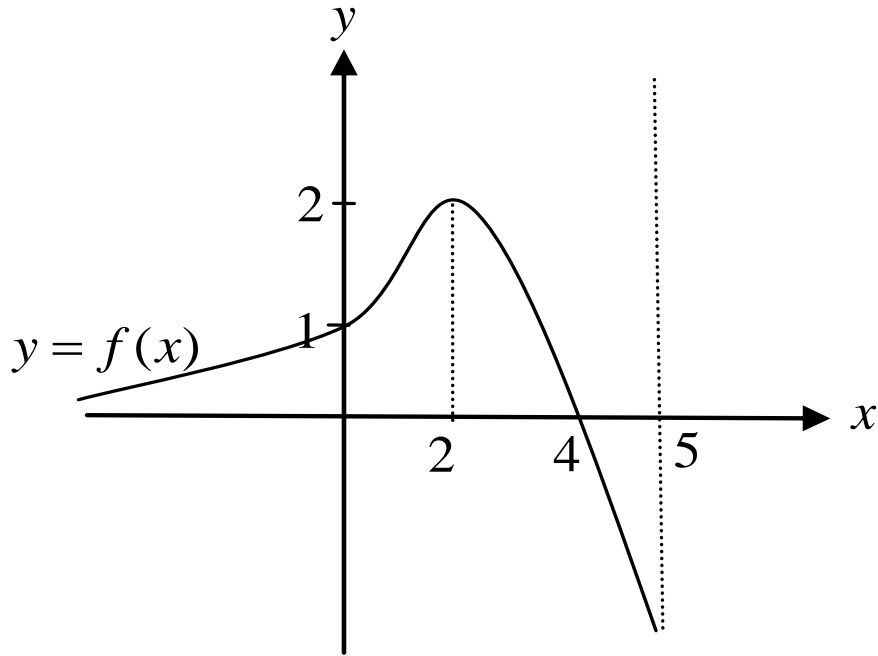

(ii) $y^2 = f(x)$

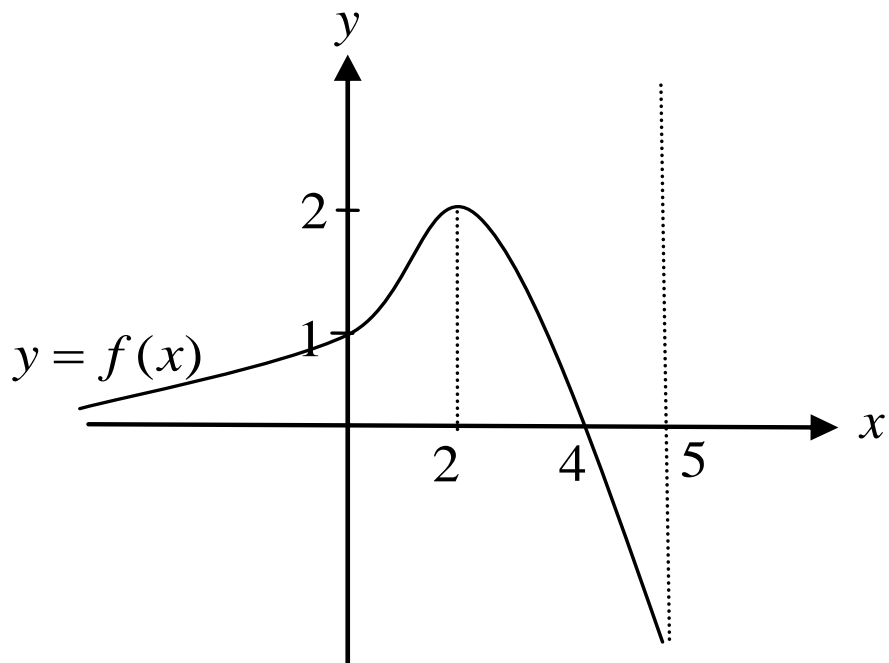

Question 4: Detach and hand in this page. STUDENT NUMBER.....

Use these sketches for your answers to question 4

(iii) $y = f(|x|)$

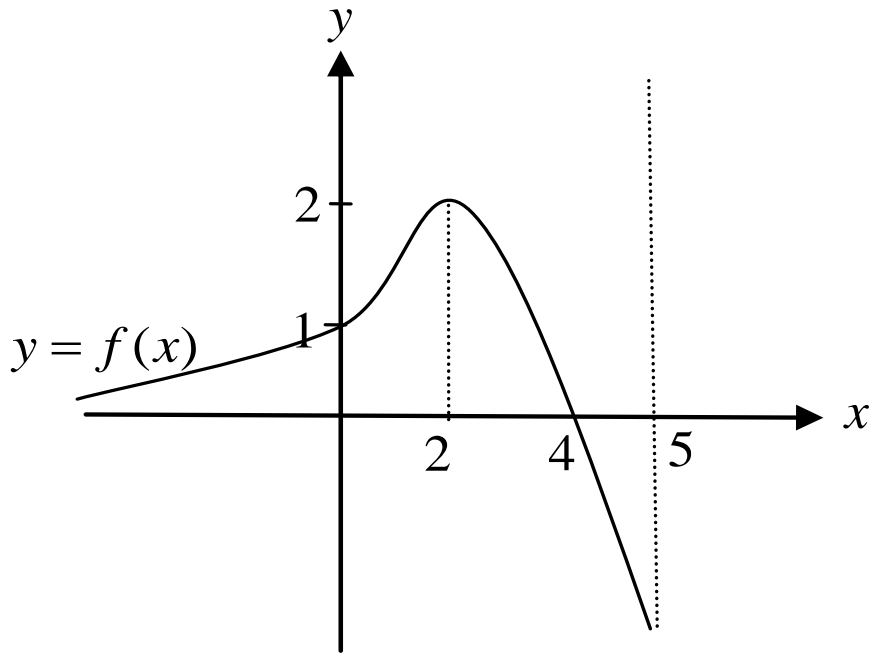

(iv) $y = [f(x)]^3$

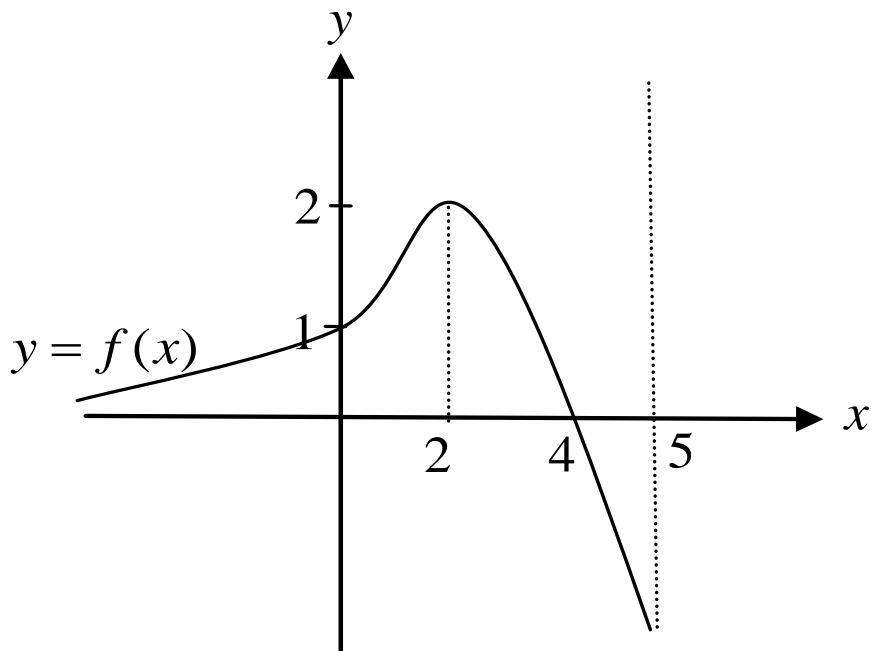

Question 7: Detach and hand in this page. STUDENT NUMBER.....

Use these sketches for your answers to question 7

(a) Diagram (I)

(i)

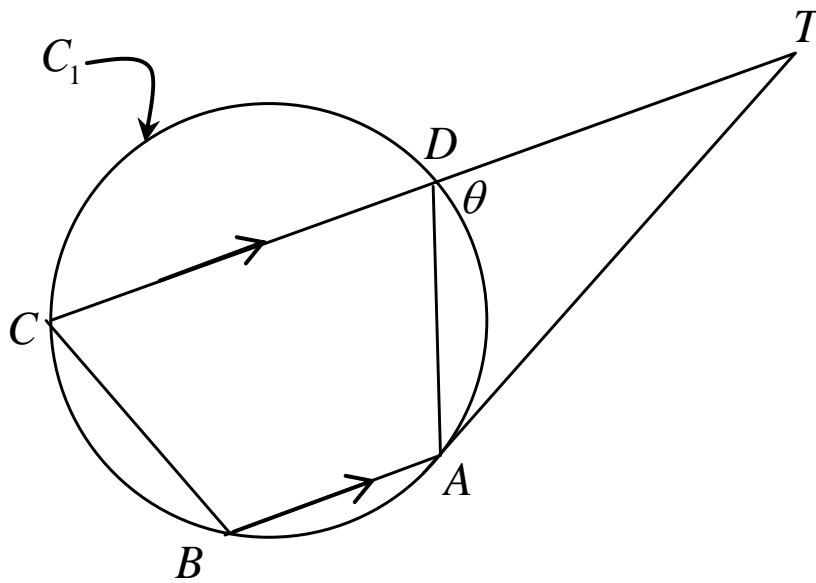

(a) Diagram (II)

(iii)

