



**ADVANCED HIGH POWER MODEL ROCKET
ASSEMBLY AND OPERATION INSTRUCTIONS**

BEFORE YOU BEGIN:

Study the illustrations and sequence of assembly. The sequence of assembly is important. Review the parts list and become familiar with all parts before assembly. If any parts are missing or damaged, contact AEROTECH™ @ (702)-641-2301 or through our web site @ www.aerotech-rocketry.com.

DO NOT MODIFY THE DESIGN OF THE ROCKET.
Changes to the design of the rocket such as, but not limited to, reducing the fin size, shortening the body tube, or modifying the motor tube assembly can adversely affect the flight stability of the rocket and may void this products warranty.

Only use AEROTECH™ Composite Model Rocket Motors in this High Power rocket. See box label for recommended motors.

**COMPLETED
SUMO™
LEVEL 1
MODEL ROCKET**

**Read And Follow
All Instructions**



**Designed by Ed LaCroix,
Jason Blatzheim,
and Bobby Rosenfield**

Read and follow the Model Rocket Safety Code of the National Association of Rocketry (NAR) and comply with all federal, state, and local laws in all activities with model rockets.

PARTS LIST

Description	Part #	Qty	Description	Part #	Qty
Cap, Piston	(14006)	1	Ejection gas baffle	(19030)	1
Sleeve, Piston	(14007)	1	Screw eye	(19015)	1
Motor tube (12"/30.5cm)	(12912)	1	Shock cord (18')	(17201)	1
Motor Hook	(19001-Y)	1	Body tube (4" x 23")	(14040)	1
FIN-LOK™ rings-4 fin	(19344)	2	Launch lugs	(19035)	2
Centering rings (3.896" O.D.)	(14029)	3	Nose cone (9 oz.)	(11405)	1
Fins	(11715)	4	Parachute (42" diameter)	(13042)	1
Bulkhead Disc (2.540")	(16609)	1	Buckle, Cord Retaining	(17150)	2
Spacer, HP Motor (Black tube)	(14015)	1	Decal Sheet	(18023)	1
Spacer, Hobby Motor (Yellow tube)	(14014)	1	Instructions, Sumo	(19924)	1

ADDITIONAL MATERIALS AND TOOLS REQUIRED

12" Ruler (with 1/16" resolution)
Medium viscosity cyanoacrylate (cyano') cement AND
5 to 15 minute cure epoxy
Hobby knife

1/8" Wood dowel at least 12" long
#240 / #400 Grit sandpaper
Masking Tape (3/4" AND 1" wide)

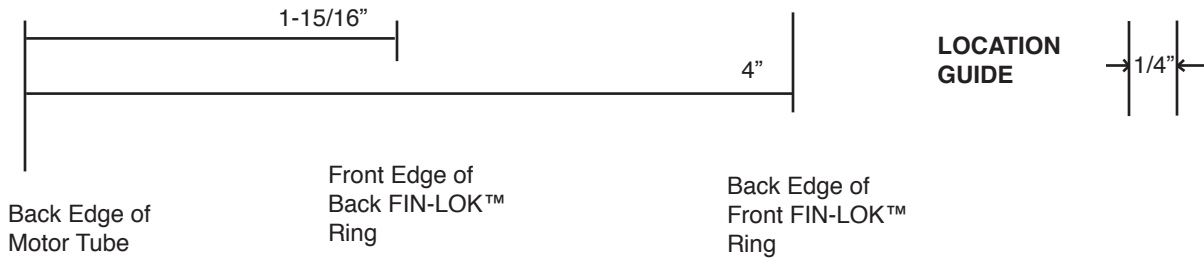

MOTOR TUBE LAYOUT

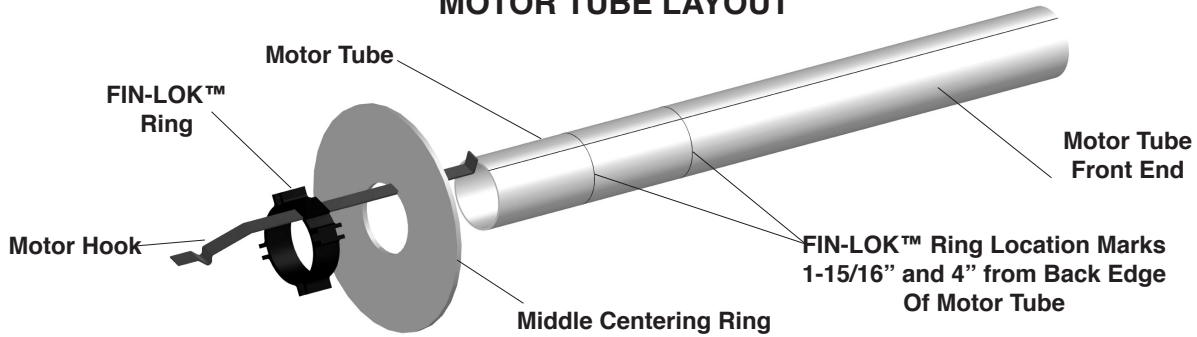

1. Using the Location Guide, make a mark along the motor tube line 4" from the **back end** of the motor tube. This mark locates where the **back edge** of the front FIN-LOK™ ring will be. Make another mark 1-15/16" from the back end of the motor tube. This mark locates where the front edge of the rear most FIN-LOK™ ring will be.

NOTE: This motor tube assembly does not require thrust rings or a slot for the motor hook. Motor spacing is accomplished with the yellow and black spacer tubes for RMS motors, or masking tape for Single Use motors. This allows the use of the widest range of motors manufactured by Aerotech. **No cooling mesh to be used.**

FIN-LOK™/ LABYRINTH ASSEMBLY

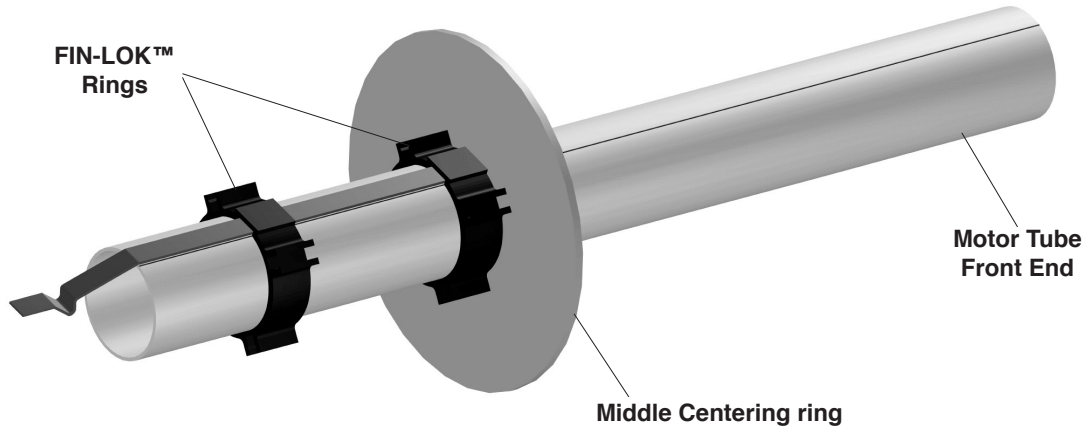

NOTE: FROM THIS POINT ON, **DO NOT USE ANY CEMENT UNTIL REACHING ASSEMBLY STEP 5.**

use a small piece of cloth to provide a better grip.)

1. Slide the motor hook, centering ring, and FIN-LOK™ ring over the **rear end** of the motor tube. The tab of the motor hook will be facing up and rest against the forward face of the centering ring. Push on the FIN-LOK™ ring until the **back edge** of the FIN-LOK™ ring is moved to the forward most mark made in Step 1 above. (**NOTE:** The rings are designed to be a tight fit on the motor tube. If the rings are difficult to slide onto the motor tube, round the inside edges of the rings with sandpaper. If the FIN-LOK™ rings need to be turned after they are on the motor tube,
2. Slide the other FIN-LOK™ ring over the **back end** of the motor tube. Push on the FIN-LOK™ ring until the **front edge** of the FIN-LOK™ ring is at the rear most mark made in Step 1 above.
3. Using the line on the motor tube as a guide, gently twist the fin locks of the back FIN-LOK™ ring until they are aligned with the fin locks of the front FIN-LOK™ ring.

FIN-LOK™ / LABYRINTH™ ASSEMBLY (CONT'D)

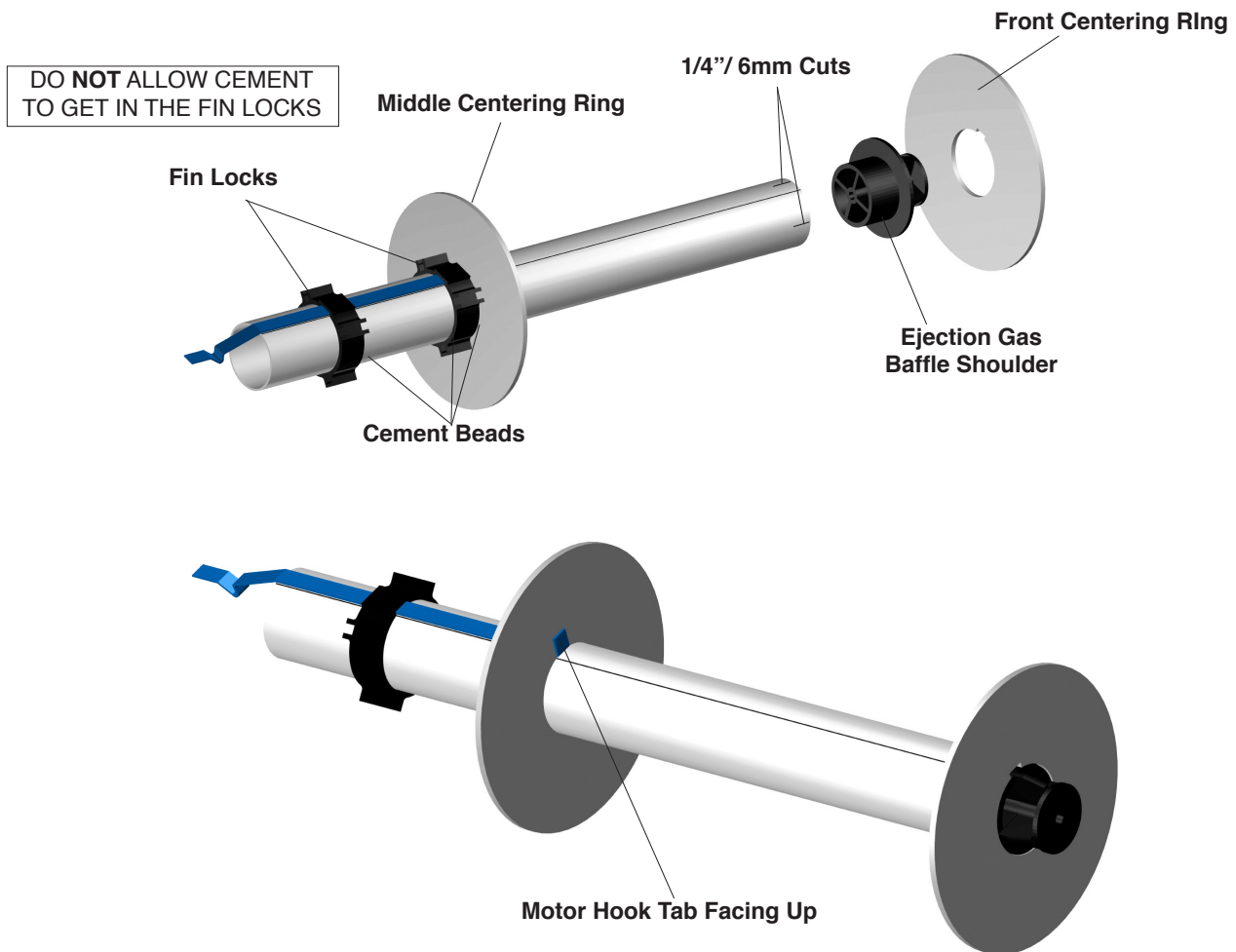

4. Test the proper positioning and alignment of the FIN-LOK™ rings by snapping the fins into the fin locks. If any fin does not snap into place, check to see that each FIN-LOK™ ring is the correct distance from the back end of the motor tube and that the fin has no plastic flashing left from production that may be preventing a proper fit. Remove any plastic flashing with a hobby knife or sandpaper. After making any adjustments, carefully remove the fins. Check that the middle centering ring is still positioned next to and touching the front FIN-LOK™ ring.
5. Apply a bead of cement where the middle centering ring meets the motor tube. Without getting cement into any of the finlocks, apply cement only to the areas BETWEEN the finlocks where the front FIN-LOK™ ring meets the middle centering ring and the motor tube.
6. Without getting cement into any of the finlocks, apply cement only to the areas BETWEEN the finlocks where only the **front edge** of the back FIN-LOK™ ring meets the motor tube. DO NOT apply cement to the back edge of the back FIN-LOK™ ring. (**NOTE:** The unique AEROTECH FIN-LOK™ fin mounting system carries and distributes aerodynamic and thrust loads throughout an integrated rocket structure in a manner found in large aerospace vehicles. Loads are primarily borne by structural members and not cement.)
7. Make four 1/4" (6mm) long cuts, 90 degrees apart, in the front end of the motor tube.
8. Apply a thin film of cement to the front 2/3rd's of the shoulder of the ejection gas baffle and insert the baffle shoulder all the way into the front of the motor tube. Cement the front centering ring on top of the ejection baffle as shown. Apply beads of cement where the baffle meets the motor tube and into each of the cuts in the motor tube.

BODY AND FIN ASSEMBLY

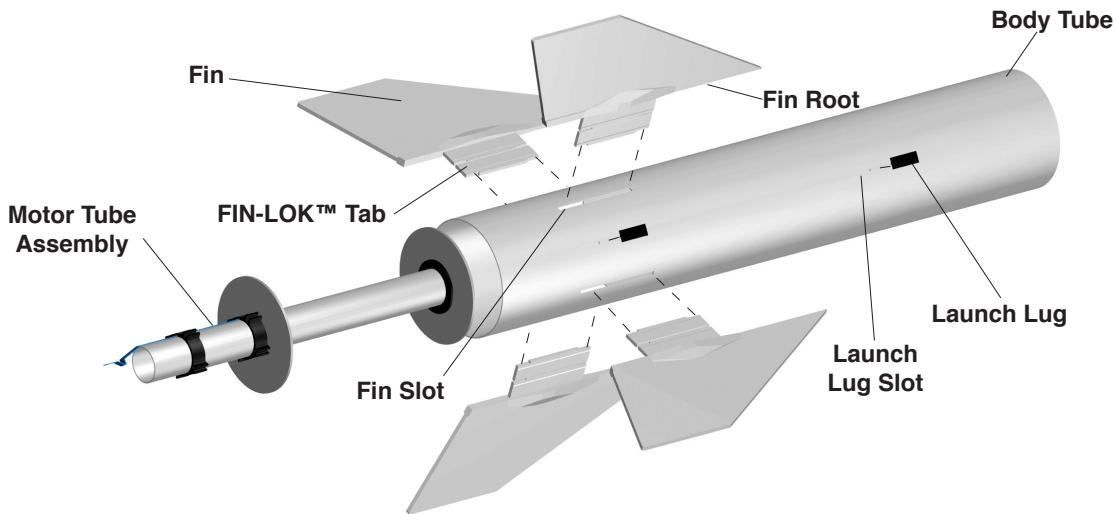

- Using a hobby knife, carefully remove any body tube material that may still be attached to any pre-cut slots in the body tube.
- Insert the motor tube assembly into the back of the rocket body tube as shown. Position the motor tube assembly so that the fin locks are located under and visible through the body tube's pre-cut fin slots.
- Apply cement along the full length of the fin root of a fin (area of the fin that makes contact with the outside surface of the body tube). Carefully insert the fin through a slot in the body tube and snap the fin into place. Repeat this process for the other three fins. Apply glue fillets at the body and fin joints.
- Through the back end of the body tube, apply cement where the fin tabs meet the motor tube, finlocks, and body tube. Through the front end of the body tube, carefully apply cement where the front centering ring meets the inside surface of the body tube. This **must be** an airtight seal.
- Lightly sand the surface of the body tube around the launch lug slots. Apply cement to the base of a launch lug. With the sloping portion of the launch lug facing toward the front of the body tube, insert the tab on the bottom of the lug into one of the pre-cut launch lug slots in the body tube. Repeat this process for the other launch lug.

(NOTE: Each fin should be snug against the body tube.)

CENTERING RING / DISC INSTALLATION

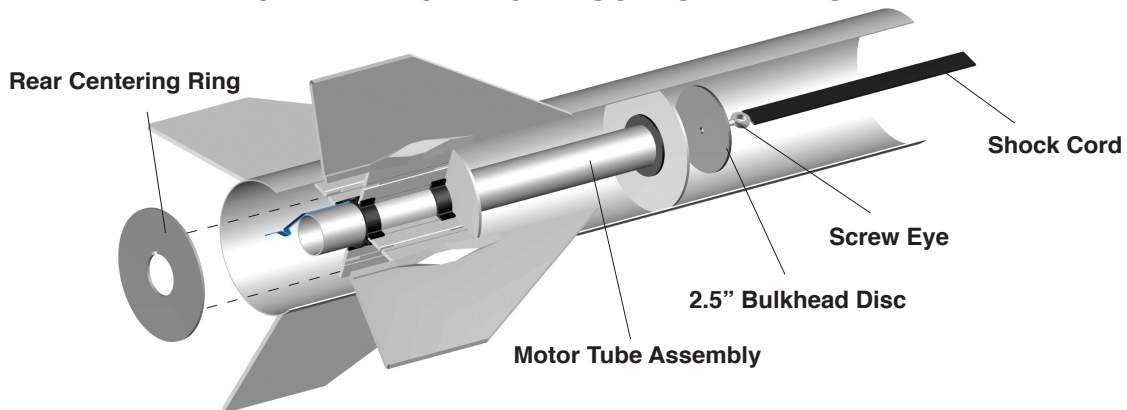

- Slide the rear centering ring over the back of the motor tube and push it against the back FIN-LOK™ ring. Apply a bead of cement where the centering ring meets the body tube and the motor tube. Securely tie an end of the shock cord to the screw eye with a square knot. Do **not** put cement on the knot of the shock cord. Screw the screw eye through the bulkhead disc and then into the hole in the ejection baffle until tight. Do **not** glue the screw eye into the ejection baffle.

PISTON ASSEMBLY

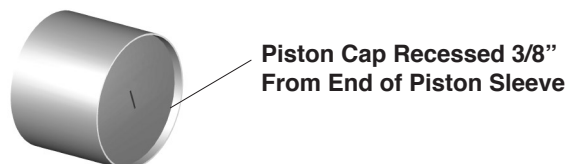

- Epoxy the Piston Cap inside the Piston Sleeve recessed 3/8" from one end. (Use the black spacer tube as a support for this operation.) When dry, apply epoxy fillets to both sides of the Cap/Sleeve joints. Do **not** allow any epoxy to drip on the outside diameter of the Piston Assembly which could interfere with its intended operational movement.

PISTON ASSEMBLY INSTALLATION

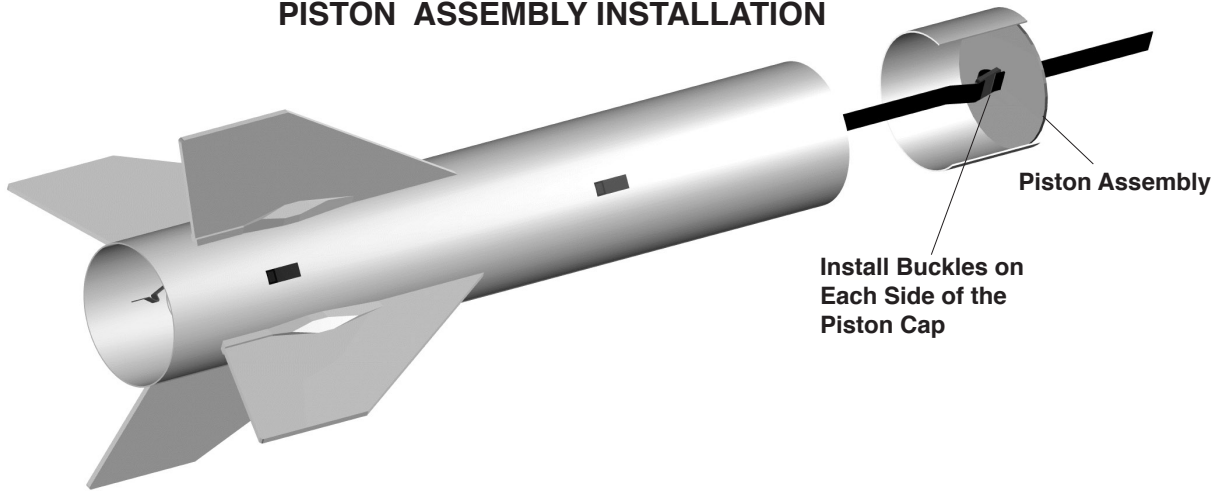

3. When the Piston Assembly is completely cured, slide one buckle over the shock cord approximately 6 feet from the end of the body tube. Then slide the Piston Assembly over the shock cord (Piston Cap facing forward as shown) and slide the other buckle over the shock cord within one inch of the Piston Assembly. Securely tie the loose end of the shock cord to the molded loop on the nose cone with a square knot. **Do not** apply cement to the knot on the shock cord.

PARACHUTE INSTALLATION

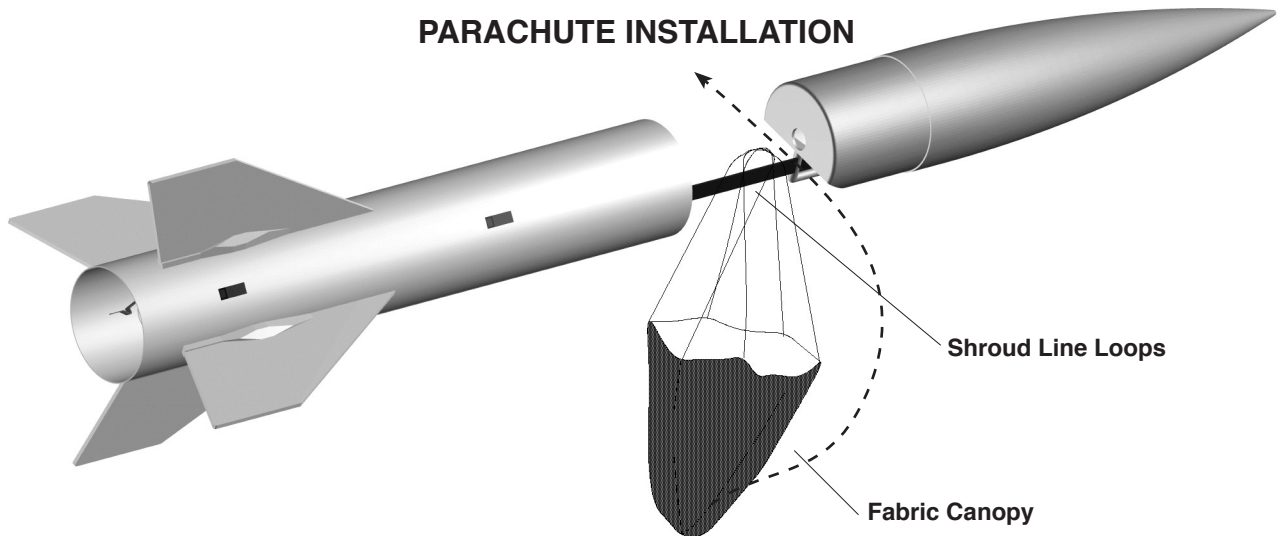

4. Fasten the fabric parachute to the shock cord at a point about one (1) foot away from the nose cone in the following manner: Stretch out the shroud lines of the parachute so that the lines form three (3) loops one on top of the other. Lay the shock cord across all the shroud lines. Pass the canopy of the parachute over the shock cord and through the three (3) loops made by the shroud lines and pull tight. Pack the parachute and insert the nose cone into the body tube.

CUTAWAY VIEW OF COMPLETED SUMO™

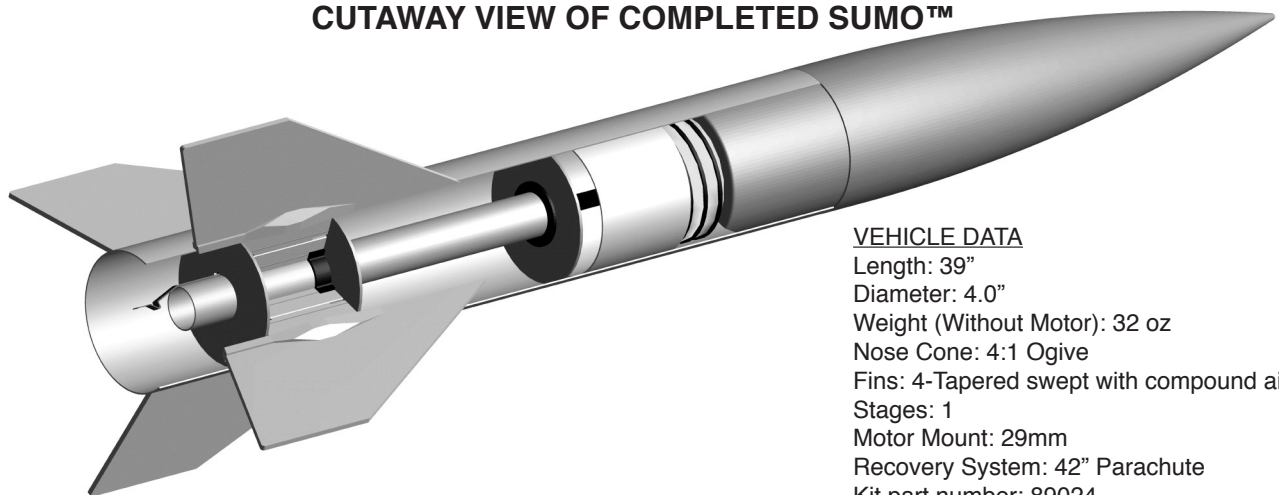

VEHICLE DATA

Length: 39"
Diameter: 4.0"
Weight (Without Motor): 32 oz
Nose Cone: 4:1 Ogive
Fins: 4-Tapered swept with compound airfoil
Stages: 1
Motor Mount: 29mm
Recovery System: 42" Parachute
Kit part number: 89024

FINISHING AND DECAL INSTRUCTIONS

Clean the rocket with a damp cloth. Paint the entire rocket with a primer coat of light gray paint. Let the primer dry. Paint the nose cone and body tube red and the fins yellow. (**CAUTION:** Make sure the paint is compatible with high impact styrene plastic.)

Reference the photograph of the completed SUMO rocket on the first page of these instructions for proper positioning. Carefully cut the decals with a sharp knife or scissors with smooth cuts. Fill a bowl with warm water and a drop of dishwashing detergent. Dip a decal into the water/detergent solution before peeling and then slide the decal of its backing and on to the rocket. This will prevent the decals from grabbing too quickly. Gently press any air bubbles out from under the decal and dab the decal dry. Apply the rest of the decals in the same manner.

OPERATION INSTRUCTIONS

1. **RECOMMENDED MOTORS:** Only use AEROTECH composite model rocket motors when flying your AEROTECH rocket. See the box label for recommended motors to be used with your SUMO™ rocket .
 2. **RECOVERY SYSTEM PREPARATION:** Bundle the aft end of the shock cord with a rubber band loosely and insert into the open end of the Piston Assembly and slide the Piston into the top of the body tube until it stops against the front centering ring. Roll the parachute and shroud lines, starting from the canopy peak, into a loose cylinder that will easily slide into the rocket body tube. Pack the long portion of the shock cord into the body tube first. Next, insert the parachute. Finally, insert the short length of shock cord into the body tube on top of the parachute and put on the nose cone. Make sure that the parachute, shroud lines, and shock cord are not caught between the body tube and the shoulder of the nose cone. The nose cone should slide freely. (**NOTE:** Extreme hot weather may make the nose cone a tight fit, however, it will function properly with the piston ejection system.)
 3. **MOTOR PREPARATION:** The motors recommended for your AEROTECH rocket vary in physical size as well as performance. Prepare your AEROTECH rocket motor according to the instructions that come with the motor. **HP 29mm RMS motors use the black spacer tube. Hobby 29mm RMS motors use the yellow spacer tube. Use 3/4" masking tape for single use motor spacing.** Be sure the motor hook snaps in behind the nozzle end of the motor and holds the motor securely in place. **Wrap 1" tape around the junction of the motor tube and the aft end of the motor to prevent any possibility of the motor ejecting with all motors.**
 4. **PRE-LAUNCH CHECKOUT:** Before **EVERY** flight, perform a complete pre-launch checkout of your rocket;

Check that all fins and launch lugs are mounted securely and not damaged. Examine the body tube and nose cone to make sure they are free of damage.

Check that the shock cord is securely mounted to the ejection gas baffle and nose cone, and is in good condition.
- See that the nose cone and piston assembly move freely. After awhile, an ejection residue will build up at the bottom inside surface of the body tube and the O.D. of the piston . Lightly sand with 400 grit sandpaper to remove any ejection charge build up.
- With the tail of the rocket pointed down and the motor tube empty, shake the rocket to remove any loose ejection charge debris left from a previous flight. Periodically, clean the inside of the motor tube to remove any ejection charge residue.
- Be certain the motor to be used is a recommended AEROTECH model rocket motor of a size appropriate for the launch area.
- Be sure the motor hook and motor tube are not damaged and hold the motor securely in place.
- If the pre-launch checkout reveals and damage, **repair the damage** before the rocket is flown again.
5. **LAUNCH PAD:** Your AEROTECH rocket must be flown from a launch pad with a 1/4" (6.4mm) diameter metal launch rod at least 36" (0.9m) long (as measured from the top of the blast deflector), and must be stable with larger rockets like the Sumo.
 6. **MOTOR IGNITION:** Only launch your rocket using a remotely controlled and electrically operated launch controller. Keep yourself and all other people at least 50 feet away from the rocket during launch.
 7. **LAUNCH AREA:** Launch the rocket in a cleared outdoor area free of tall trees, power lines, and buildings. The side dimensions of the cleared area should be at least one half of the projected altitude. An area for a radius of at least 5 feet (1.5 meters) from the launcher should be clear of dry grass or other flammable substances. Read and follow the Model Rocket Safety Code of the National Association of Rocketry (NAR) and comply with all federal, state, and local laws in all activities with model rockets. A copy of the NAR safety code is shown on the instructions that come with all AEROTECH composite rocket motors.
 8. **FLIGHT PROFILE:** When the launch button of the electrical launch controller is pressed, an electrical current causes the igniter to ignite the composite propellant of the AEROTECH rocket motor. The motor quickly builds up thrust and powers your AEROTECH rocket into the air. During powered flight the rocket increases in speed and altitude. When the propellant burns out the rocket is moving at maximum velocity and a time delay material (delay grain) inside the motor burns. While the delay grain burns the rocket coasts to peak altitude at which point the delay grain ignites the ejection charge within the forward part of the motor. The ignition of the ejection charge creates a burst of hot expanding gas which flows around the baffle, and is cooled by the bulkhead disc attached to the front of the ejection baffle, and then pressurizes the parachute bay and ejects the piston, nose cone and parachute. The parachute then deploys and gently returns the rocket to the ground where the rocket can be prepared for another flight.
 9. **TRANSPORT AND STORAGE:** To avoid damage to your AEROTECH rocket during transport, pack it in a box surrounded by soft packing. Store your rocket at room temperature.

NOTICE: AEROTECH certifies that it has exercised reasonable care in the design and manufacture of its products. As we cannot control the storage and use of our products, once sold we cannot assume any responsibility for product storage, transportation, or usage. AEROTECH shall not be held responsible for any personal injury or property damage resulting from the handling, storage, or use of our product. The buyer assumes all risks and liabilities therefrom and accepts and uses AEROTECH products on these conditions.

No warranty either expressed or implied is made regarding AEROTECH products, except for replacement or repair, at AEROTECH's option, of those products which are proven to be defective in manufacture within one year from the date of original purchase. For repair or replacement under this warranty, please contact AEROTECH. Proof of purchase will be required. Note: Your state may provide additional rights not covered by this warranty.

ATTENTION!

BEFORE FLYING YOUR



PLEASE READ THE FOLLOWING!

The AeroTech SUMO advanced model rocket **MUST** be flown with either a AeroTech single-use “G” or “H” motor or RMS™ “G” or “H” reload kit. Please see the box label for recommended propulsion.

Additionally, the AeroTech SUMO, when fully prepared for launch, will weigh more than one (1) pound. When flying a model rocket that weighs over one (1) pound at liftoff you **MUST** observe certain FAA regulations.

BE AWARE!

Federal Aviation Administration (FAA) regulations (FAR 101-subpart C) currently require that anyone planning to launch a model rocket weighing over one (1) pound but no more than 3.3 pounds at liftoff **MUST** notify (such as by a telephone call) the nearest FAA Air Traffic Control (ATC) facility no less than 24 hours and no more than 48 hours in advance of the launch of such a rocket and provide the following information:

- a) The names and addresses of the operators; except when there are multiple participants at a single event; the name and address of the person so designated as the event launch coordinator, whose duties include coordination of the required launch data estimates and coordinating the launch event;
- b) The estimated number of rockets to be operated;
- c) The estimated size and estimated weight of each rocket; and
- e) The location of the operation.
- f) The date, time, and duration of the operation.

Rockets weighing over one (1) pound but no more than 3.3 pounds at liftoff must not be launched within 5 miles of an airport runway or other landing area **unless** the information listed above is also provided to the manager of that airport.

In addition, no person may operate an unmanned rocket that weighs over one (1) pound but no more than 3.3 pounds at liftoff:

- 1) In a manner that creates a collision hazard with other aircraft.
- 2) At an altitude where clouds or obscuring phenomena of more than five/tenths coverage prevails.
- 3) At any altitude where the horizontal visibility is less than five (5) miles.
- 4) Into any cloud.

Read and follow the Model Rocket Safety Code of the National Association of Rocketry (NAR) and comply with all federal, state and local laws in all activities with model rockets.

PLEASE FLY SAFELY!

SPECIAL CONSTRUCTION AND OPERATING INSTRUCTIONS

The Aerotech Sumo™ is a Level 1 ready rocket kit that requires extra attention to construction details and operational techniques. Please be certain before flying your Sumo rocket that you have inspected all of these critical assembly steps and follow these pre and post flight inspections:

(1) All fins **must** have a glue fillet applied between the root edges and the body tube to withstand the forces of high power motors.

(2) The front centering ring **must** have an airtight seal at the junction of the body tube to prevent any ejection gas from escaping to the area around the motor tube. Make certain that there is no glue inside the body tube that could hinder the operational motion of the piston assembly.

(3) The bulkhead disc (heat shield) **must** be in place securely with the screw eye attached. It can be temporarily removed for the cleaning of ejection residues inside of the body tube and for shock cord replacement.

(4) The proper spacers are used with both hobby motors (yellow), high power motors (black), and 3/4" masking tape is applied to the nozzle end of the case for single use motors. Without these in place the motors will move forward during flight and adversely affect center of gravity.

(5) The motor hook **must** be in place behind all motors and you **must** then tape the junction between the aft closure / aft end of the motor and the motor tube with at least 1" masking tape **very** securely. This prevents any ejection gas from escaping around the motor tube and will prevent the motor from ejecting from the motor tube. Failure to perform this step may result in the piston assembly not functioning properly and not ejecting the parachute.

(6) Although Aerotech high power "H" reload kits contain a pre-measured amount of black powder (1.4 grams), only use 1/2 of the supplied amount. The proper amount has been determined to be between **.7 and 1.0 grams** for the piston ejection system. Using more than this amount may lead to premature wear and/or failure of the shock cord. Standard Aerotech "G" class single use motors and G64 reloads can be used as supplied.

(7) **INSPECT** the entire length of the shock cord **after every flight** for any visible damage by stretching and observing for any weak spots. Replace all damaged shock cords before attempting next flight. This is considered a wear part and is easily replaced.