



mirage

ADVANCED MODEL ROCKET

Assembly and Operation Instructions

BEFORE YOU BEGIN:

- Study the illustrations and sequence of assembly. The sequence of assembly is important. Review the parts list and become familiar with all parts before assembly. If any parts are missing or damaged, contact AEROTECH™ at 1-702-641-2301.
- **DO NOT MODIFY THE DESIGN OF THE ROCKET.** Changes to the design of the rocket such as, but not limited to, reducing the fin size, shortening the body tube, or modifying the motor tube assembly can adversely affect the flight stability of the rocket.
- Only use AEROTECH™ Composite Model Rocket Motors in this model rocket. See Motor Matrix for recommended AEROTECH™ motors.

Read and follow the Model Rocket Safety Code of the National Association of Rocketry (NAR) and comply with all federal, state and local laws in all activities with model rockets.

PARTS:

Thrust Ring (7/16"/11mm)	(14010)	1
Thrust Ring Flange (1/16"/1.6mm)	(14011)	1
Motor Tube	(12912)	1
Motor Hook	(19001)	1
FIN-LOK Rings (3 Fin)	(19343)	2
Centering Rings (2-17/32"/64mm)	(16629)	3
Fins	(11715)	3
Cooling Mesh	(19011)	1
Ejection Gas Baffle	(19030)	1
Screw Eye	(19015)	2
Shock Cord (8')	(17388)	2
Lower Body Tube (Slotted)	(12625)	1
Middle Body Tube w/Launch Lug Slot	(12627)	1
Upper Body Tube (Unslotted)	(12626)	1
Bulkhead Disk (1/16"/1.6mm)	(16609)	1
Coupler Tube (6"/15cm)	(12606)	2
Launch Lugs	(19035)	2
Nose Cone	(11261)	1
Decal Sheet	(18019)	1
22" Parachute (Upper Body Section)	(13022)	1
30" Parachute (Lower Body Section)	(13030)	1
'F' Spacer Tube (1")	(14003)	1
Instructions	(19919)	1

ASSEMBLY INSTRUCTIONS:

(Use medium viscosity cyanoacrylate cement.)

COMPLETED
MIRAGE™
ADVANCED
MODEL
ROCKET

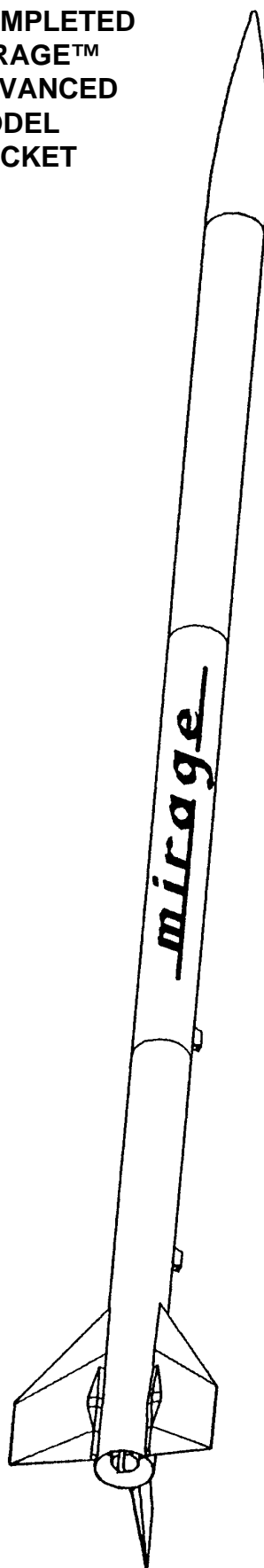

**Read And
Follow All
Instructions**

*Designed by
Bob Sanford*

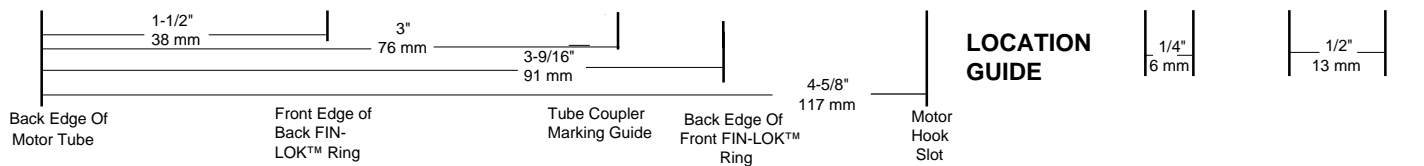

MOTOR TUBE ASSEMBLY

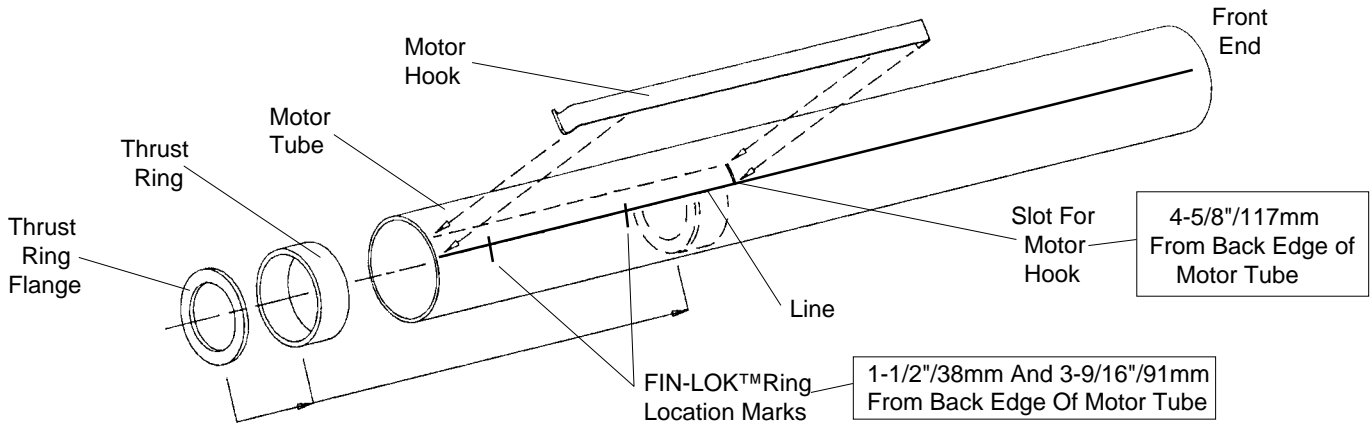

1. Cement the thrust ring flange (1/16"/1.6 mm thick) to the thrust ring (7/16"/11 mm long). Set the thrust ring assembly aside to dry.
2. Find the line drawn along the side of the motor tube. Using the Location Guide printed along the top edge of this instruction sheet, cut a 1/4" (6 mm) long slot 4-5/8" (117mm) from the back end of the motor tube and next to the line on the motor tube as shown.
3. Using the Location Guide, make a mark along the motor tube line 3-9/16" (91mm) from the **back end** of the motor tube. This mark locates where the **back edge** of the front FIN-LOK™ ring will be. Make another mark 1-1/2" (38mm) from the **back end** of the motor tube. This mark locates where the **front edge** of the rear most FIN-LOK™ ring will be.
4. Insert the tab of the motor hook into the slot cut into the motor tube. **Use a small dowel to apply several drops of cement around the inside of the motor tube just behind where the motor hook comes through the motor tube wall.** Then, with the thrust ring flange facing the back of the motor tube, insert the thrust ring assembly into the motor tube until it stops, against the motor hook tab.

FIN-LOK™ ASSEMBLY

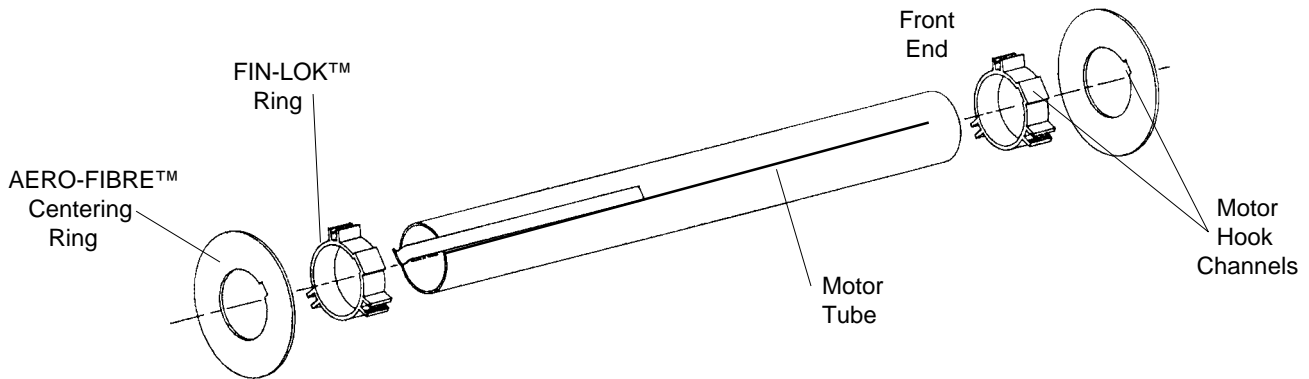

NOTE: FROM THIS POINT ON, DO NOT USE ANY CEMENT UNTIL REACHING ASSEMBLY STEP 5.

after they are on the motor tube, use a small piece of cloth to provide a better grip.)

1. With their motor hook channels aligned with the motor hook, slide a FIN-LOK™ ring and then an AERO-FIBRE™ centering ring over the **front end** of the motor tube. Push on the centering ring until the **back edge** of the FIN-LOK™ ring is moved to the forward most mark made in Step 3 above. (**NOTE:** The rings are designed to be a tight fit on the motor tube. If the rings are difficult to slide onto the motor tube, round the inside edges of the rings with sandpaper. If the FIN-LOK™ rings need to be turned
2. Slide the other FIN-LOK™ ring and then a centering ring over the **back end** of the motor tube. Push on the centering ring until the **front edge** of the FIN-LOK™ ring is at the rear-most mark made in Step 3.
3. Using the line on the motor tube as a guide, gently twist the back centering ring slightly until the fin locks of the back FIN-LOK™ ring are aligned with the fin locks of the front FIN-LOK™ ring.

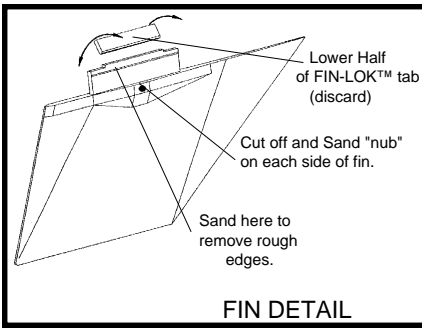

FIN-LOK™ ASSEMBLY (CONT.)

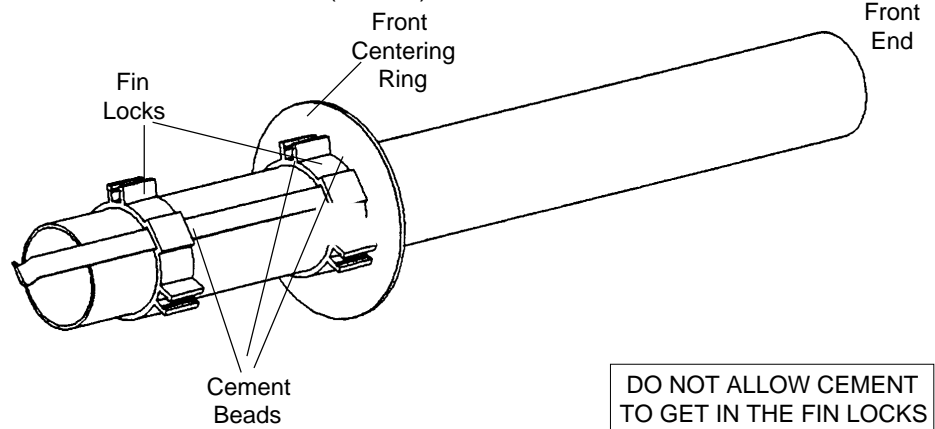

- Use a pair of pliers to snap off the lower half of the FIN-LOK™ tab from each of the three (3) fins as shown. Discard the pieces that were broken off. Sand the edge of the tabs to remove any rough edges from where the lower half of the fin tabs were removed. Cut and sand the nub on each side of the fin smooth.
- Test the proper positioning and alignment of the FIN-LOK™ rings by snapping the fins into the fin locks. If any fin does not snap into place, check to see that each FIN-LOK™ ring is the correct distance from the back end of the motor tube and that the fin has no plastic flashing left from production that may be preventing a proper fit. Remove any plastic flashing with a hobby knife or sandpaper. After making any adjustments, carefully remove the fins **and the back centering ring**. Check that the front centering ring is still positioned next to and touching the front FIN-LOK™ ring.
- Apply a bead of cement where the front centering ring meets the motor tube. Without getting cement into any of the finlocks, apply cement only to the areas **BETWEEN** the finlocks where the front FIN-LOK™ ring meets the front centering ring and the motor tube.
- Without getting cement into any of the fin locks, apply cement only to the areas **BETWEEN** the fin locks where only the **front edge** of the back FIN-LOK™ ring meets the motor tube. **DO NOT** apply cement to the back edge of the back FIN-LOK™ ring. (**NOTE:** The unique AEROTECH FIN-LOK™ fin mounting system carries and distributes aerodynamic and thrust loads throughout an integrated rocket structure in a manner found in large aerospace vehicles. Loads are primarily borne by structural members and not cement.)
- Apply a bead of cement around the motor hook forward of the front centering ring.

LABYRINTH™ ASSEMBLY

DO NOT CEMENT COOLING MESH INTO MOTOR TUBE

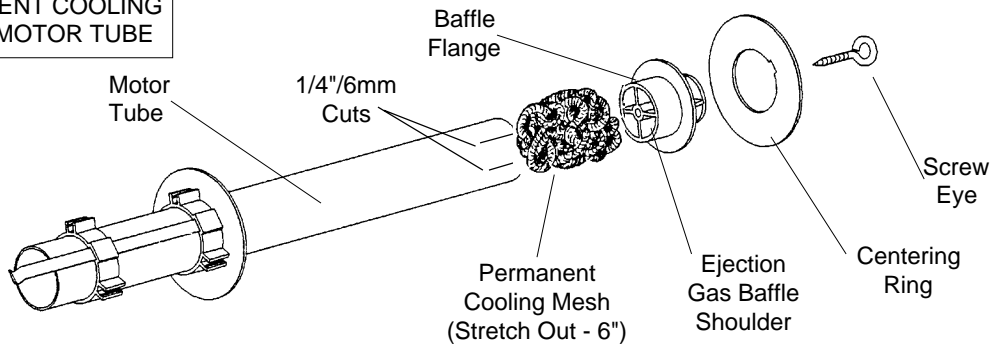

- Make four 1/4" (6mm) long cuts, 90 degrees apart, in the front end of the motor tube.
- Stretch out the cooling mesh to about 6" (15cm) in length. Insert the cooling mesh into the **front end** of the motor tube. (**NOTE:** Do **not** cement the mesh into the motor tube.)
- Apply a **thin film** of cement to the front 2/3rd's of the shoulder of the ejection gas baffle and insert the baffle shoulder into the front end of the motor tube.
- Apply beads of cement where the baffle meets the motor tube and into each of the cuts in the motor tube.**
- Apply cement to the front surface of the baffle flange and place an AERO-FIBRE™ centering ring over the front end of the baffle so it rests upon the baffle flange.
- Screw the screw eye all the way into the hole at the front end of the baffle. Securely tie an end of the shock cord to the screw eye with a square knot. (**CAUTION:** Do **not** put cement on the knot of the shock cord. Cement will weaken the shock cord.)

LOWER BODY AND FIN ASSEMBLY

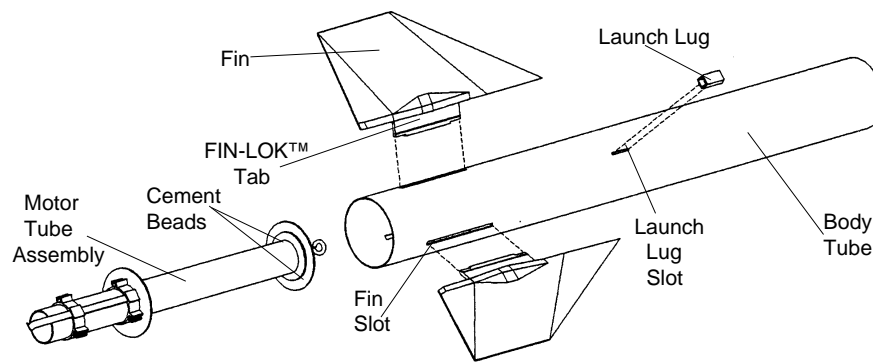

- Using a hobby knife, carefully remove any body tube material that may still be attached to any pre-cut slots in the body tube.
- Insert the loose end of the shock cord and then the motor tube assembly into the back of the rocket body tube as shown. Position the motor tube assembly so that the fin locks are located under and visible through the body tube's pre-cut fin slots.
- Apply cement along the **full length** of the fin root of a fin (area of the fin that makes contact with the outside surface of the body tube). Carefully insert the fin through a slot in the body tube and **snap** the fin into place. Repeat this process for the other two fins. (**NOTE:** Each fin should be snug against the body tube.)
- Through the back end of the body tube, apply cement where the fin tabs meet the motor tube, fin locks, front centering ring and body tube. Through the front end of the body tube, apply cement where the baffle assembly centering ring meets the inside surface of the body tube.
- Lightly sand the surface of the lower body tube around the launch lug slot. Apply cement to the base of a launch lug. With the sloping portion of the launch lug toward the front of the lower body tube, insert the tab on the bottom of the lug into the pre-cut launch lug slot in the lower body tube.

UPPER BODY ASSEMBLY

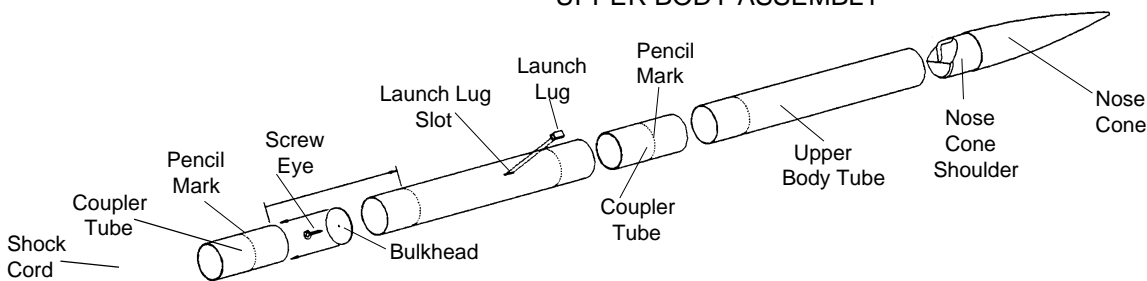

- Screw the other screw eye all the way into the hole in the bulkhead (1/16"/1.6 mm thick). Apply a bead of cement where the screw eye meets the bulkhead.
- Pass the free end of the shock cord through the coupler tube (6"/15 cm long) and securely tie it to the screw eye attached to the bulkhead with a square knot. (**CAUTION:** Do not put cement on the knot or the shock cord. Cement will weaken the shock cord.)
- Cement the bulkhead to the end of the coupler tube.
- Make a pencil mark 3" (76 mm) from an end of the coupler tube using the location guide. Lightly sand the surface of the tube between the mark and the bulkhead. Use a small dowel to apply a bead of cement around the inside of the middle body tube about 1" (25 mm) from the end of the tube. Then slide the coupler tube into the middle body tube up to the pencil mark on the coupler tube.
- Make a pencil mark 3" (76mm) from an end of the remaining coupler tube using the location guide. Lightly sand the entire surface of the coupler tube. Use a small dowel to apply a bead of cement around the inside of the upper body about 1" (25mm) from the end of the tube. Then slide the coupler tube into the upper body tube up to the pencil mark on the coupler tube. Allow time for the cement to dry. Use a small dowel to apply a bead of cement around the inside of the open end of the middle body tube from Step #5. Then slide the coupler tube/upper body assembly into the middle body tube until it stops. Allow the cement to dry before moving the joined tubes.
- Using a hobby knife, carefully remove any body tube material that may still be present in the launch lug slot in the middle body tube. Lightly sand the surface of the middle body around the launch lug slot. Apply cement to the base of the remaining launch lug. With the sloping portion of the launch lug toward the front of the body tube, insert the tab on the bottom of the lug into the pre-cut launch lug slot in the middle body tube.
- Cement the nose cone into the forward end of the upper body tube.

FINAL ASSEMBLY AND FINISHING

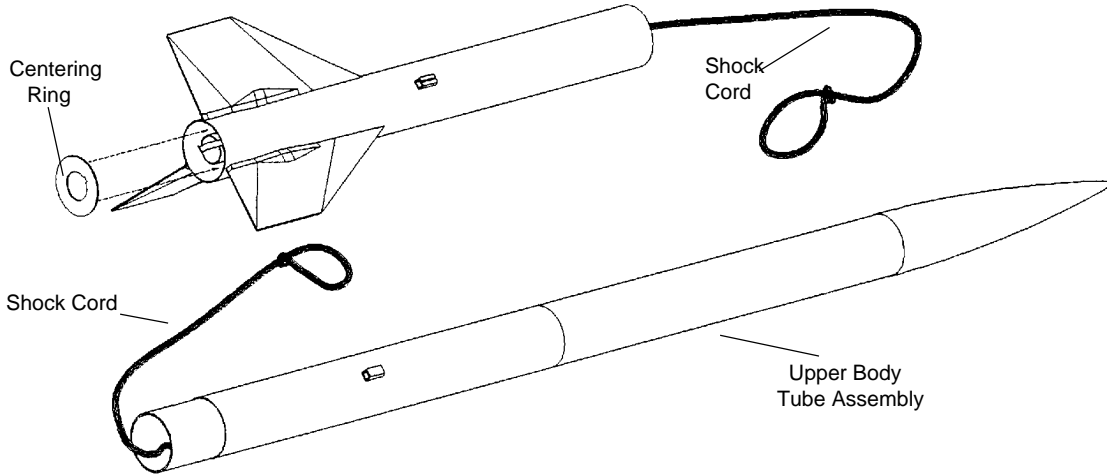

- Slide the remaining centering ring over the back of the motor tube and motor hook and push it against the back FIN-LOK™ ring. Apply a bead of cement where the centering ring meets the body tube.
- Clean the rocket with a damp cloth. Paint the entire rocket with a primer coat of paint (gray or white). Let the primer dry. Paint entire rocket with glossy black paint or your own choice of colors. **(CAUTION: Make sure the paint is compatible with high impact polystyrene plastic.)**
- Carefully cut out the self adhesive decal and apply it to the middle body tube with the "m" being placed 7" (175mm) from the back of the body tube. See "Decal Instructions" for helpful hints.
- Tie loops in the ends of both shock cords. Thread the 30" (76cm) parachute shroud lines through the loop in the lower body tube shock cord. Stretch out the shroud lines of the parachute so that the lines form three (3) loops on top of the other. Pass the canopy of the parachute through the three (3) loops made by the shroud lines and pull tight. Repeat this procedure with the 22" (56cm) parachute and the upper body assembly.

CUTAWAY VIEW OF COMPLETED MIRAGE™

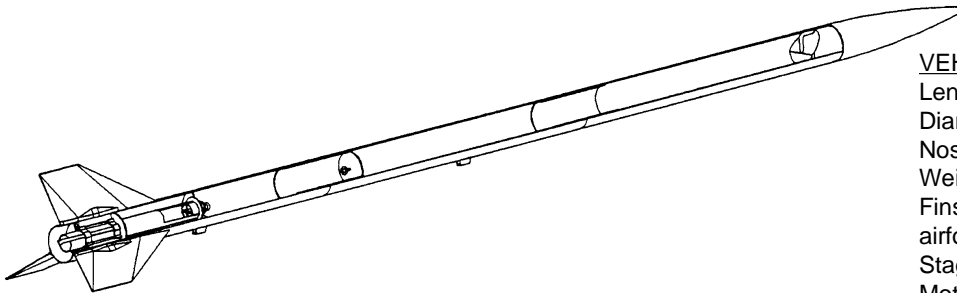

VEHICLE DATA

Length: 87"/220cm
 Diameter: 2.6"/6.7cm
 Nose Cone: 5:1 Ogive
 Weight (Without Motor): 31oz/880 gms.
 Fins: 3 Tapered swept with compound airfoil
 Stages: 1
 Motor Mount: 29mm
 Recovery System: Parachute

DECAL INSTRUCTIONS

- Handle the decal sheet carefully to avoid damage. Do not crease the decal sheet.
- Use a pair of sharp scissors or a hobby knife to cut out the decals.
- Cutting out decals that will be positioned close together on the rocket as one block will make them easier to apply.
- Make smooth cuts. Small knicks can cause a decal to tear when it is being peeled off the backing sheet.
- Before starting to peel decals off their backings, fill a soup bowl with warm water and put one or two drops of a dishwashing detergent into the water.
- Carefully peel a decal off its backing, dip it into the detergent solution and apply the decal to the rocket. The detergent solution prevents the adhesive on the decal from "grabbing" the rocket surface too quickly and allows accurate positioning of the decal.
- Gently press any air bubbles out from under the decal and then dab the decal dry.
- Apply the rest of the decals in the same manner.

OPERATION INSTRUCTIONS

1. **RECOMMENDED MOTORS:** Only use AEROTECH composite model rocket motors when flying your AEROTECH rocket. See enclosed chart for recommended motors and projected altitudes.
2. **RECOVERY SYSTEM PREPARATION:** Roll the parachute and shroud lines for the upper body assembly. Start from the canopy peak and roll this parachute and shroud lines into a tight cylinder that will easily slide into the lower body tube/fin unit. Place this parachute into the lower body tube followed by the shock cord. Roll the parachute and shroud lines for the lower body tube/fin unit. Start from the canopy peak and roll this parachute and shroud lines into a loose cylinder. Pack the lower body assembly parachute on top of the upper body parachute and shock cord previously installed in the rocket. Pack the upper body shock cord on top of this parachute. Insert the remaining shock cord length into the body tube and insert the coupler tube for the upper body assembly. Make sure that the parachutes, shroud lines and shock cords are not caught between the body tube and the shoulder of the upper body assembly. The upper body unit should slide freely. (NOTE: Because your AEROTECH rocket has the LABYRINTH™ ejection gas cooling system, no recovery wadding is required.)
3. **MOTOR PREPARATION:** The motors recommended for your AEROTECH rocket vary in physical size as well as performance. Your rocket comes with a changeable motor adaptor and spacer tubes that permit the rocket to use each of the recommended motors without permanent modification to the rocket.

Prepare your AEROTECH rocket motor according to the instructions that come with the motor. Be sure the motor hook snaps in behind the nozzle end of the motor and holds the motor securely in place. If the motor hook does not hold the motor in place, bend the end of the hook until it does.

4. **PRE-LAUNCH CHECKOUT:** Before **EVERY** flight, perform a complete pre-launch checkout of your rocket;
 - Check that all fins and launch lugs are mounted securely and not damaged.
 - Examine the body tube, nose cone and payload bay to make sure they are free of damage.
 - Check that the shock cord is securely mounted to the ejection gas baffle and nose cone (or payload bay bulkhead).
 - Check that the parachute is securely tied to the shock cord.
 - Check that the shock cord and parachute are free of any damage.
 - See that the nose cone (or payload bay), packed parachute and shock cord move freely. After awhile, an ejection charge residue may build up at the top inside surface of the body tube. Wipe this residue away with isopropyl ("rubbing") alcohol.
 - With the tail of the rocket pointed down and the motor tube empty, shake the rocket to remove any loose ejection charge debris left from a previous flight. Periodically, fluff up the cooling mesh using a bent wire inserted through the back end of the motor tube.
 - Be certain the motor to be used is a recommended AEROTECH model rocket motor and of a size appropriate for the launch area.
 - Be sure the motor hook, motor adaptor and motor tube are not damaged and hold the motor securely in place.

If the pre-launch checkout reveals any damage, **repair the damage** before the rocket is flown again.

5. **LAUNCH PAD:** Your AEROTECH rocket must be flown from a launch pad with a 1/4"(6.4mm) diameter metal launch rod at least 36"(0.9m) long (as measured from the top of the blast deflector), such as the AEROTECH MANTIS™ model rocket launch pad.
6. **MOTOR IGNITION:** Only launch your rocket using a remotely controlled and electrically operated launch controller such as the AEROTECH® INTERLOCK™ model rocket launch controller. Keep yourself and all other people at least 30 feet (10 meters) away from the rocket during launch.
7. **LAUNCH AREA:** Launch the rocket in a cleared outdoor area free of tall trees, power lines and buildings. The side dimensions of the cleared area should be at least one half of the projected altitude. An area for a radius of at least 5 feet (1.5 meters) from the launcher should be clear of dry grass or other flammable substances. Read and follow the Model Rocket Safety Code of the National Association of Rocketry (NAR) and comply with all federal, state and local laws in all activities with model rockets. A copy of the NAR safety code is shown on the instructions that come with all AEROTECH composite model rocket motors.
8. **FLIGHT PROFILE:** When the launch button of the electrical launch controller is pressed, an electrical current causes the AEROTECH COPPERHEAD™ single lead igniter to ignite the composite propellant of the AEROTECH rocket motor. The motor quickly builds up thrust and powers your AEROTECH rocket into the air. During powered flight the rocket increases in speed and altitude. When the propellant burns out the rocket is moving at maximum velocity and a time delay material (delay grain) inside the motor burns. While the delay grain burns the rocket coasts to peak altitude at which point the delay grain ignites the ejection charge within the forward part of the motor. The ignition of the ejection charge creates a burst of hot expanding gas which is cooled by the permanent metal mesh of the LABYRINTH™ ejection gas cooling system. The cooled gas flows around the baffle, pressurizes the parachute bay and ejects the nose cone (or payload bay) and parachute. The parachute then deploys and gently returns the rocket to the ground where the rocket can be prepared for another flight.
9. **TRANSPORT AND STORAGE:** To avoid damage to your AEROTECH rocket during transport, pack it in a box surrounded by soft packing. Store your rocket at room temperature.

NOTICE: AEROTECH certifies that it has exercised reasonable care in the design and manufacture of its products. As we cannot control the storage and use of our products, once sold we cannot assume any responsibility for product storage, transportation or usage. AEROTECH shall not be held responsible for any personal injury or property damage resulting from the handling, storage or use of our product. The buyer assumes all risks and liabilities therefrom and accepts and uses AEROTECH products on these conditions.

No warranty either expressed or implied is made regarding AEROTECH products, except for replacement or repair, at AEROTECH's option, of those products which are proven to be defective in manufacture within one year from the date of original purchase. For repair or replacement under this warranty, please contact AEROTECH. Proof of purchase will be required. Note: Your state may provide additional rights not covered by this warranty.

ATTENTION!

READ THIS BEFORE FLYING YOUR MIRAGE™

The AEROTECH MIRAGE™ Advanced Model Rocket loaded with an AEROTECH "F" or "G" motor weighs more than one (1) pound at liftoff. When flying a model rocket that weighs over one (1) pound at liftoff you must observe certain FAA regulations.

Federal Aviation Administration (FAA) regulations (FAR 101-subpart C) currently require that anyone planning to launch a model rocket weighing over one (1) pound but no more than 3.3 pounds at liftoff must notify (such as by telephone call) the nearest FAA Air Traffic Control (ATC) facility no less than 24 hours and no more than 48 hours in advance of the launch of such a rocket and provide the following information:

- a) The names and addresses of the operators; except when there are multiple participants at a single event; the name and address of the person so designated as the event launch coordinator, whose duties include coordination of the required launch data estimates and coordinating the launch event;
- b) The estimated number of rockets to be operated;
- c) The estimated size and estimated weight of each rocket; and
- d) The estimated highest altitude or flight level to which each rocket will be operated.
- e) The location of the operation.
- f) The date, time, and duration of the operation.
- g) Any other pertinent information requested by the ATC facility.

Rockets weighing over one (1) pound but no more than 3.3 pounds at liftoff must not be launched within 5 miles of an airport runway or other landing area unless the information listed above is also provided to the manager of that airport.

In addition, no person may operate an unmanned rocket that weighs over one (1) pound but no more than 3.3 pounds at liftoff:

- 1) In a manner that creates a collision hazard with other aircraft.
- 2) At an altitude where clouds or obscuring phenomena of more than five/tenths coverage prevails.
- 3) At any altitude where the horizontal visibility is less than five (5) miles.
- 4) Into any cloud.

Read and follow the Model Rocket Safety Code of the National Association of Rocketry (NAR) and comply with all federal, state and local laws in all activities with model rockets.

FLY SAFELY!

©1999 AeroTech, Inc., All rights reserved.