

800 STEREO MIXER

OWNER'S MANUAL

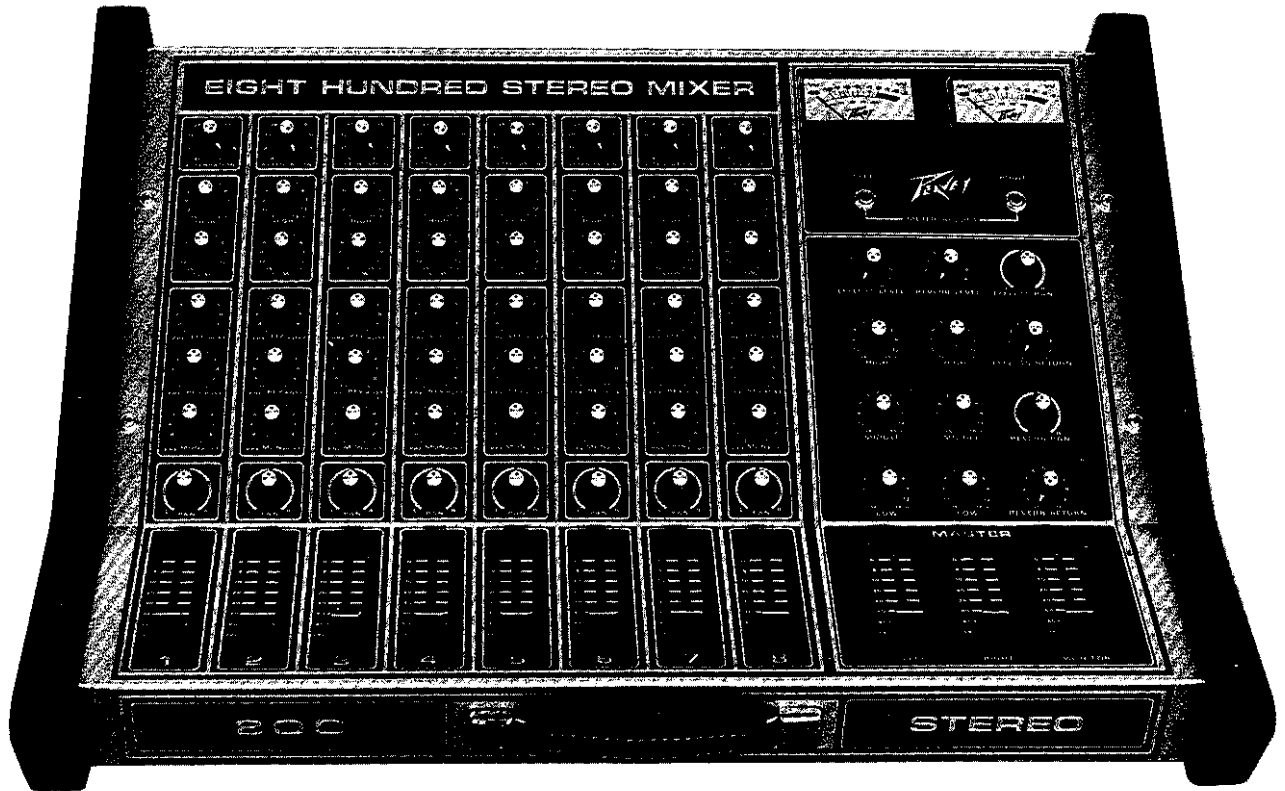

FREQUENCY RESPONSE:

20 Hz - 20 kHz ± 2 dB @ 2v RMS output (+8 dBM)

TOTAL HARMONIC DISTORTION:

Less than 0.1% THD 20 Hz - 10 kHz @ +8 dBM output

EQUIVALENT INPUT NOISE:

High Z input, -80 dB below 2v RMS @ 20 dB gain
Low Z input, -120 dBV @ 150 ohms (1 μ V)

CROSSTALK:

-50 dB @ 1 kHz

INPUTS:

Low impedance unbalanced microphone 600 ohm (cannon plug)
High impedance unbalanced line 50 K ohm (phono plug)

INPUT ATTENUATOR:

Continuously variable from 0 dB to -40 dB selectable on mic or line inputs
Total gain of mixer @ 0 dB attenuation = 66 dB

OUTPUTS:

Main and Monitor
Unbalanced, 3v RMS into 2 K ohms, balanced, 600 ohms +12 dBM, short circuit protected

EFFECTS HIGH:

Unbalanced, 2 v RMS into 10 K ohms

EFFECTS LOW:

Unbalanced, 0.4v RMS into 10 K ohms

EQUALIZATION:

Infinitely variable boost and cut, ± 15 dB @ 50 Hz and 5 kHz each channel, ± 15 dB @ 50 Hz, 800 Hz, and 5 kHz

EFFECTS:

Built-in reverb unit with contour control effects out and return capability for external effects unit



The 800S mixer has been designed and built using the most modern and innovative circuitry available in order to bring to the market a fully professional mixer at a reasonable price. Our constant research into audio circuitry as well as attention to the latest methods of electronics packaging combine to produce the 800S mixer's basic concepts. We talked with many sound contractors as well as sound people who are involved with sound reinforcement about the **real** needs and requirements of a mixer before actually beginning our design.

We began by finding out what features were actually needed on the job while giving second priority to features that "would be nice to have." The design goal of the 800S was to produce an entirely functional unit without the many "frills" that console designers sometimes include, thus running up the price considerably while adding little or nothing to the performance and/or utility of the unit.

Examination of the various features of the 800S will illustrate that its control panel has been very carefully thought out and includes the most needed functions to professionally handle sound reinforcement applications. Below, each feature is described as to function as well as operational characteristics.

INPUT CIRCUITRY

In addition to the low impedance mic inputs, we have provided **high impedance** (50K OHM) **MIC inputs** (28). These high level inputs have a very wide dynamic range and are capable of accepting the line outputs from tape machines or other devices as well as being very suitable for use with conventional high impedance microphones.

The **input attenuator** (1) is located at the top of each channel area and enables the operator to pad (attenuate) the input signal to a level that will not overload the input preamp.

In use, the operator must set the input attenuation in such a manner that input overload clipping is avoided. This can be easily done by setting up the channel with the highest expected input signal level and adjusting the input pad so that no clipping or distortion is heard from the speaker system. After the console has been used several times, the operator will have a very good idea of the signal levels encountered and will be able to set up the input pads accordingly. The different types of microphones will have different output levels and different performers will get widely varying levels from mics depending on the strength of their voices and/or their basic "mic techniques."

The input attenuator/pad should be operated in the position yielding the **least attenuation** required to avoid clipping. Operation in this mode allows maximum gain to be utilized in the input preamp where it is most efficiently obtained. Excessive input padding sometimes makes necessary higher settings of the channel gain controls and/or master controls thus yielding a less than optimum signal-to-noise ratio for any given situation.

It is important to realize that not all "breakup" is caused by the mic signal overloading the front end of the console. If the performer's mic technique includes very close and/or very loud situations, the internal elements of the mic can "bottom out" or distort just as a loudspeaker can when it is overdriven. Quite a few of the mics now used by performers lack the dynamic range required to adequately handle the tremendous sound pressure levels encountered in a very loud rock

concert. It is vital for the professional sound man to be aware of the limitations of the various links in the audio system in order to correctly diagnose and solve the various problems encountered in a sound reinforcement situation.

Overall, the input attenuator is the first control in the circuit and must be set up properly in order for the remaining circuits to function properly. "Common Sense" and experience on several jobs will allow the operator of the 800S to achieve superb results in virtually any mixdown situation.

The equalization circuitry of the 800S mixer is the latest active type, utilizing negative feedback technology. We selected circuitry that produces a "shelving" type of action because the conventional type circuitry tends to create erratic, or sometimes harsh-sounding results when in the near-maximum boost positions. These two equalization controls will produce extremely smooth action as well as giving effective tone control action. Experience will show their utility in achieving professional channel equalization on the job.

It should be remembered that these active equalization circuits are a form of "electronic crossover" in which the equalization controls are similar to level controls for their respective frequency bands.

Generally, it is poor operating practice to use both equalizer controls in the deep cut (counter-clockwise) positions since this results in substantially lower gain from the channel. It should be remembered that the balance of highs and lows is a **relative** situation and cutting overall channel gain should properly be done either by the input pad or the output slide attenuator.

The **low frequency equalizer** (3) is capable of better than 15 Db boost or cut @ 50 Hz with a sloping characteristic exhibited up to the crossover point. The shelving action of this control has proven to yield a much more satisfying and effective equalization characteristic than some of the "wide open" equalization circuits claiming 20-25 Db boost and cut. The action of this equalization control is conventional and should present absolutely no problem in operation. Boost is obtained in the righthand (clockwise) while cut is obtained in the lefthand (counter-clockwise) position. The vertical (12 o'clock) position yields a flat (no boost or cut) response and is the position from which all tonal balancing should be started.

The **high-frequency equalizer** (2) is capable of 15 Db boost or cut @ 5 KHZ with a shelving characteristic sloping-down to the crossover point. The boost or cut action of this control is very similar to that of the low equalizer with the exception of its high frequency effect. Boost is obtained to the right of center position while cut is obtained to the left of center position. Flat response is obtained in the center (12 o'clock) position.

Caution should be exercised in using excess low-frequency boost to avoid emphasizing objectionable wind noises or rumble from the microphone as well as any hum that might enter the mixer from external sources. Excessive treble boost should be avoided to keep residual noise from the amplification circuitry to a reasonable level as well as to avoid a strident or screeching tonality in the output program material.

In sound reinforcement, there is nothing holy about an entirely flat equalization setting. If it is necessary to use moderate amounts of equalization, then you should be willing to do so considering that the "ideal" flat settings are almost never used, even in the recording studio, and even less often in most sound

reinforcement applications.

In countless interviews with professional sound people about requirements for the 800S mixer program, the desire for complete PRE/POST send controls was one of the most wanted features. We have answered the demand for the pre/post capability by the utilization of a unique split control which yields a pre fader signal to the left of center position, a post fader send signal to the right of center setting. The center (12 o'clock) position yields a no-send signal from the channel into the send buss.

The pre/post capability of the 800S mixer is one of the most important of its many features, and it allows flexibility unmatched by most sound reinforcement mixers regardless of price. By allowing Monitor, effects, and reverb sends to be set up as pre or post sends, we achieve many special effects, such as auxiliary monitors, solo or cue capabilities, as well as normal or slaved monitoring capabilities. Experimentation will illustrate the tremendous flexibility of this simple but effective pre/post control system.

Reverb send control (5) is the channel level control for determining the amount of signal from each respective channel to be mixed into the reverb summing buss. In the vertical (12 o'clock) position, the send is off and no signal is mixed from the channel into the reverb system. Rotation in the left-hand (counter-clockwise) direction yields increasing signal levels completely **independent** of the settings of the channel's output fader, since this mode results in the signal being derived before or **pre** the output fader. Right-hand or clockwise rotation yields increasing reverb send derived after or **post** the output fader. When using the send controls in the **post** position remember that the send levels will vary up and down with the settings of the output fader.

The **effects send control (4)** operates exactly as the reverb send with the exception that its output is fed into the effects summing buss. This effects buss can be used as an auxiliary monitor output, or to drive various effects units, phasers, echo units, etc. Counter-clockwise rotation yields **pre** fader signal while clockwise rotation yields **post** fader signal. In the post position, the effects send acts as a sub-fader control following increases and decreases in output fader settings.

The **Monitor send control (6)** is the channel mixing element for determining the all-important main monitor mix. The pre/post capability of this send control is absolutely the MOST important feature of the send control area. Having pre or post capability on the monitor allows flexibility rarely available in any but the most expensive studio mixing consoles. Operation of the monitor send control is exactly the same as the Reverb and Effects controls described above. Having the **pre capability** is absolutely VITAL on the monitor send to avoid feedback of the monitor system when normal incremental output variations are made in the channel fader during the course of performance.

Experimentation and experience with the send section of the 800S will illustrate its versatility and flexibility in allowing many different variations in setup and operation of the three send controls. It should be remembered that all of these send busses operate into the main output controls for the **Reverb (10)**, **Effects (9)**, and **Monitor (23)**, which are located in the master area. No output from the various send busses will appear from their respective output jacks on the back panel unless the master controls are adjusted for

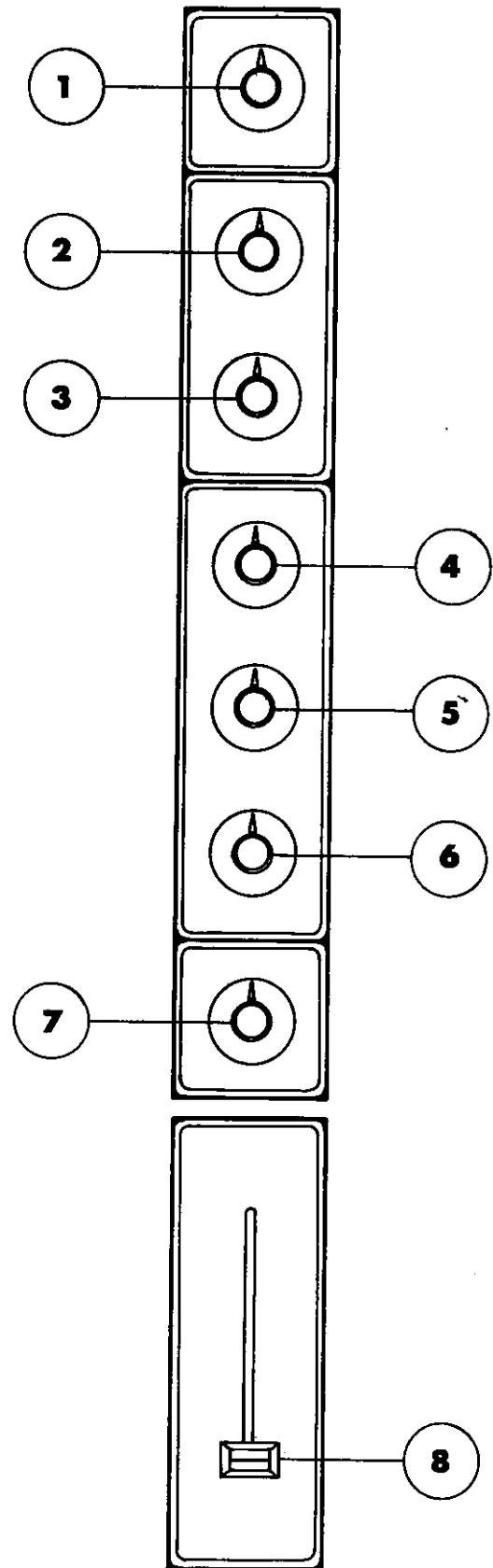

greater than zero output regardless of the settings of the individual channel's send controls.

The **stereo pan (7)** is the control used to achieve the desired balance from each individual channel into the left and right main output mixing busses. The pan control may be thought of as a kind of balance control determining the signal sent to either of the stereo outputs of the 800S.

The **channel attenuator slider** (8) is the output level control that determines the mix into the main (left and right) mixing busses. Its calibration is in decibels of attenuation and this is why the numbering sequence goes from off (infinity = ∞), or maximum attenuation to Zero (0), or no attenuation. Remember that attenuation is the **cutting** or reduction of the signal level or, the more attenuation, the more you have cut down the signal level. The Output fader is calibrated in accordance with standard practice for professional Audio equipment.

Proper settings of the input pad (attenuator) should produce adequate gain within the input preamp to allow slider settings approximately in the center (approximately -40 to -20 db.). You should remember that the input attenuator is a kind of **pre** gain control and its setting will most definitely influence the settings for the output slider with any given input signal. The input pad should be adjusted for the **maximum gain** that will allow **distortion free** performance, **then** the output slider level should be adjusted for proper mix.

It is very poor operating practice to use the input pads in the extreme cut positions and then have to set the output sliders in their close to maximum positions to obtain adequate channel output. This type of operation results in less than optimum signal-to-noise ratios as well as contributing to headroom problems. As with any system, "common sense" must be combined with operating knowledge to produce satisfactory results. Overall, the channel controls should be set to provide a reasonable amount of "adjustment" i.e., none of the gain controlling elements (input pad/output slider) should be operated near their extreme up or down positions. After several hours usage, the operator will have acquired a good "feel" for the characteristics of the controls and should be able to suitably handle any mixdown situation encountered in the field with satisfactory results.

The Master area of the 800S Mixer contains all the Master or final output controls for the five mixing busses. The **left** (21) and **right** (22) **main mixing busses** feature three section equalizations, utilizing shelving type **low** ($\frac{3}{4}$) and **high** ($\frac{1}{16}$) EQ, and peaking type **mid-frequency** ($\frac{2}{16}$) Equalization. The **Reverb** (10) and **Effects** (9) levels are the master controls for their respective mixing busses. The **reverb level** (10) serves not only to set the drive to the Internal Ac-cutronics (Hammond) Reverb delay line, but also to set the output level from the **reverb output jack** (38) on the rear panel. The **effects** (17) and **reverb return** (20) controls serve as input level controls for the two return jacks on the rear panel. You will note that we have provided **PAN controls** ($\frac{15}{18}$) for both the effects and reverb returns to allow for **true stereo** operation of these functions. This feature is especially helpful in stereo recording applications when using these two returns for "extra inputs."

The master level controls for the five internal mixing busses of the 800S should be set in such a manner that they are close to the center of their travel to take advantage of maximum control action. It is poor practice to run the channel output faders up near maximum and then run the main faders near the low end to achieve the desired output levels. Operation in this manner will cause the operator to loose his "range" in control action with all the gain located in one element while the other is near its stop position. Best practice calls for most controls to be operated in their middle or slightly higher

positions to allow maximum mixing control margins (travel). Remember, in mixing you **MUST** allow yourself adequate margins within which to operate and by using any of the faders in their extreme (close to the stop) positions, you have effectively reduced your range of control. This manner of operation also tends to create "headroom" problems.

These master controls allow the operator complete flexibility for functions and should allow almost any mixing situation to be handled by the 800S. As with any reasonably complex system, experience and operator knowledge of the equipment are essential for satisfactory performance. The mixer, like the musician's instrument, should be practiced on and learned. To properly operate a mixing console during a performance requires thorough knowledge and trained reflexes to allow proper responses under the stress of demanding and sometimes sudden "IN CONCERT" situations. The musician should know his console almost as well as he knows his instrument, so that his reactions will be both smooth and proper to correct whatever problem or requirement that should arise during a performance... A **professional** must work at it!!!

The **Left** (21) and **Right** (22) **Master output faders** are the controls that determine the main output levels for the output connectors located on the rear panel. The main summing amps, as well as those for the other three summing busses, are of the very latest "zero null" type using negative feedback to achieve maximum dynamic range, lowest noise, and crosstalk. These master faders should be operated in accord with the proper operating practices as outlined above. Experimentation and experience on several jobs will allow the operator to achieve a "Feel" for the right settings for his requirements.

The **Master Left** (14) and **Right** (15) **low frequency equalizers** are capable of 15 Db boost or cut @ 50 Hz. These equalizers are similar to those used in the individual channels and are designed to exhibit a "shelving" characteristic which has proven to yield the best results in this type application. The controls are "flat" with no boost or cut in the straight up (12 o'clock) position with boost being obtained in right-hand (clockwise) positions, and cut obtained in left of center (counter-clockwise) positions. Care should be taken **not** to overboost with the master controls. Since each channel is equipped with equalization, it is poor practice to use too much additional boost in the master section. Overboosting on low frequencies will impart a boomy and muffled tonality to the program material and will substantially decrease the intelligibility of voices being mixed through the console.

The **Master Left** (12) and **Right** (19) **Middle Frequency controls** are capable of 15 db boost or cut @ 800 Hz and are designed to exhibit a "peaking" characteristic which has been found to yield best performance in this application. The action of these controls is similar to that of the other EQ controls on the console. (Left for cut, center for flat, and right for boost.) These middle controls are **very** important in achieving a pleasing tonality to your overall sound and experience has shown that the best results occur when this middle EQ is used in the **cut** position. Rarely will you find it necessary to boost the midrange unless it's for some special effects. **Cutting the midrange slightly tends to yield a very tight and concise tonality that is extremely pleasing for voices and aids intelligibility considerably.** Actually, when you operate this middle

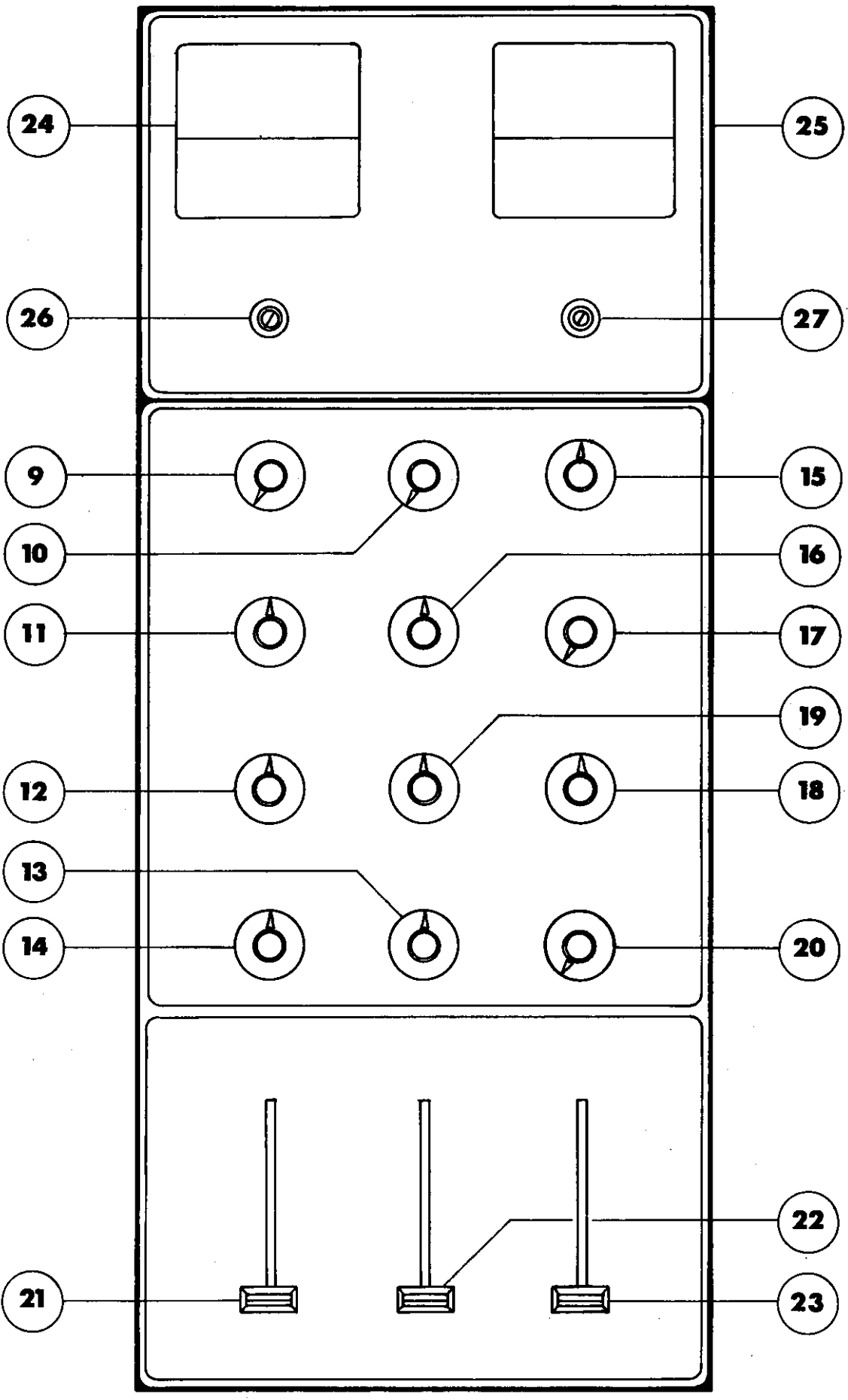

EQ control in the cut position, you are effectively reducing the amount of equalization in the mid band and causing the low and high EQ to come in farther out on each end of the spectrum. Experimentation, once again, is the key to proper use of the middle equalizers.

The **Master Left (11) and Right (16) HIGH frequency equalizers** are capable of 15 DB boost or cut @ 5 KHZ and are designed to exhibit a "shelving" characteristic. The operation of these equalizers is similar to those described above with the exception of the fact that they control the high frequency portion of the audio spectrum. Care should be taken not to overboost the high frequencies to avoid undue amplification of residual system noise (hiss) as well as creating a "strident" or screechy sounding system. High frequency overboost also tends to create undue acoustic feedback. When balancing ANY of the equalizers for proper tonality you always start with **all** equalizers in their flat (12 o'clock) positions and work from there. After you have spent several hours working with any particular setup of mics, performers, etc., you will acquire a good working equalization setup and be able to achieve the desired tonality.

The important thing to keep in mind about the equalization on the 800S is that each channel is provided with its own set of EQ controls to correct problems in that particular channel, while Master EQ is provided to allow for overall tonal balance and feedback control. We have not included these equalization systems to allow tremendous boost or cuts but rather to allow incremental EQ where it is needed. You must use common sense in the use of these controls in order to achieve satisfactory tonal balance and intelligibility.

The **Effects Level (9)** is the control that determines the overall signal output level for the effects send buss. This effects buss may be used as an auxiliary monitor send, or as a means for using various effects such as echo units, phasers, digital delay lines, etc. The output jack is located on the rear panel and has a maximum output level of 3 volts RMS @ 10K ohms output impedance. This Effects level control must be adjusted so that the output level from the jack on the rear panel does not overload the input circuitry of the effects unit you are driving, thus causing clipping or other forms of distortion. This is especially critical on some of the special effects units that are designed to work with guitars or other instruments with relatively low output levels.

The **Reverb Level Control (10)** determines the drive to the internal reverb delay lines and acts as a master for the reverb mixing buss. No reverb drive will occur unless this level control and the channel reverb send controls are turned up. It is possible to use the **reverb line output (38)** on the rear panel as an additional output if the reverb mix should be needed for some other purpose such as additional monitors, etc. The output level from this reverb output is 3 volts RMS @ 10K Ohm impedance.

The **Effects Return (17)** is the gain control for the effects return input jack located on the rear panel. This effects return input enables the signal from an external source to be mixed back into the main (left and/or right) mixing busses. This effects return is similar to an auxiliary input and actually may be used as such. This feature is intended to be used with effects or other devices that are used in conjunction with the effects output. In other words, the output to the external signal processing equipment is from the effects output, and

the signal return from the external unit should be brought into the effects return whose level is controlled by the Effects Return Control.

The **Effects Pan (15)** is the control that enables the operator to place the signal from the effects level control on either, both, or any combination in between the left and right main channels. This panning capability **must** be present to retain **true stereo** capability for the 800S. The action of this pan control is similar to those on the individual channels and should present no problem in operation.

The **Reverb Return (20)** is the gain control element for the reverb system which normally consists of the internal delay line unless the switching jack for the reverb return has been plugged into. We have designed a system that provides an automatic patching facility for the internal reverb with the added flexibility of being able to accept signals from outside sources. This is accomplished by use of a switching jack on the rear panel (reverb return). If it should be necessary to use the reverb mixing buss for other purposes, we have designed in the flexibility to allow this option.

The **Monitor Master Fader (23)** is the output level control for the main monitor system. The same operating practices should be observed when using this control as when using the main channel controls. The individual channel monitor send controls should be set in such a manner that will allow the monitor master slider (fader) to be operated somewhere in the middle of its travel to allow yourself adequate control margins, up or down, as might be required on the job. The monitor output signal is presented on the rear panel at the 600 ohm balanced connector as well as at the unbalanced phone jack monitor output.

We did not include monitor equalization in the 800S mixer since this equalization is usually contained in the monitor amplifier and is best performed on the stage itself, which is generally at some considerable distance from the console. It is because the console is usually located remotely from the performing stage that it is sometimes difficult for the monitor equalization to be performed at the console. You will find the level of the monitor output is sufficient to drive any commercial power amp or monitor system and the availability of a transformer-balanced monitor output is a valuable asset when doing the bigger jobs.

REAR PANEL

The 800S Mixer is provided with adequate input and output connectors to allow virtually any combination of mics and auxiliary equipment. Every needed feature has been included, often at considerable expense, to allow maximum flexibility. For example, we have included an entire effects mixing buss and associated input and output circuitry rather than simply patching out each individual channel as done on some "professional" mixers. Each channel features both a **low impedance input (29)** as well as a **high level input (28)**. Complete external access has been provided to **all five** of the 800S mixing busses to allow paralleling (stacking) as well as enabling any external signal source of the proper level and impedance to be patched into any of these 5 busses. The three main outputs have **transformer balanced (33)** as well as **unbalanced outputs (32)**, with adequate output levels to drive any commercial amplifier or tape recorder to full

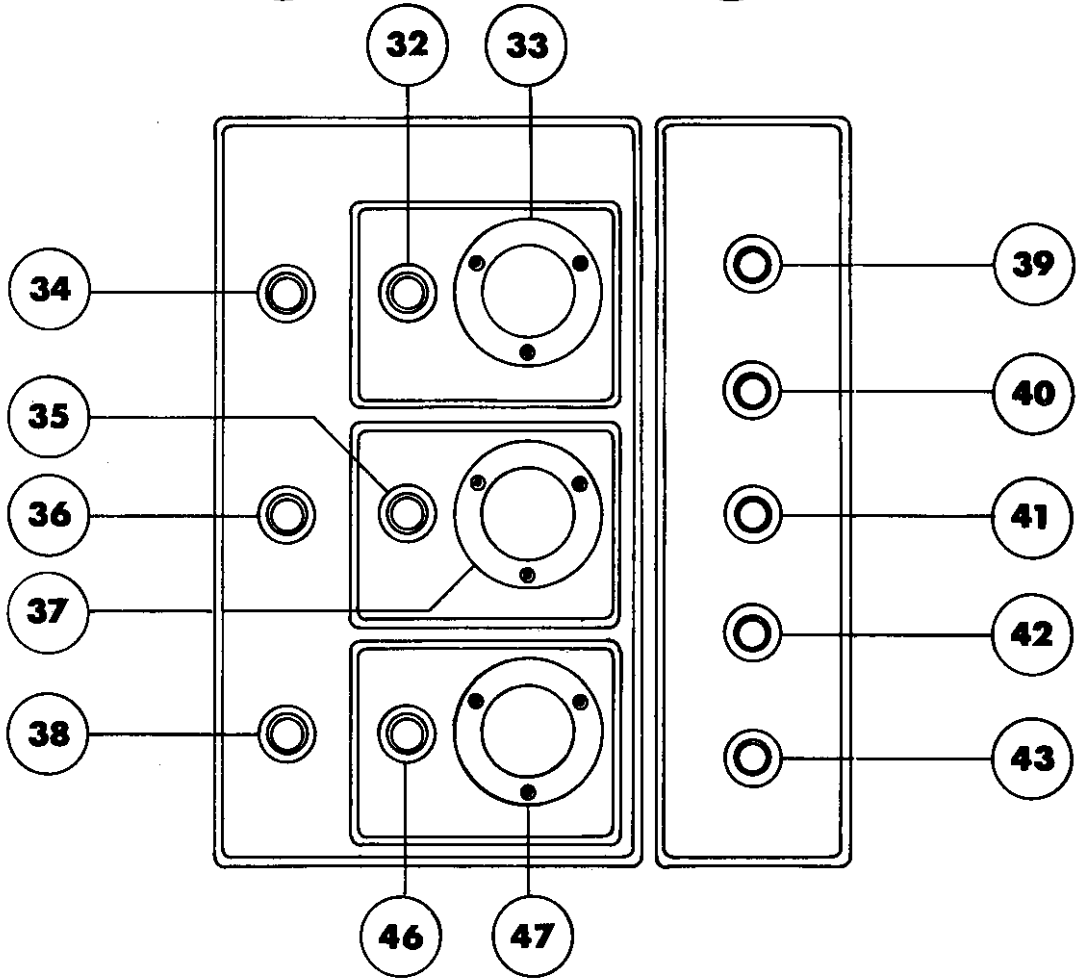
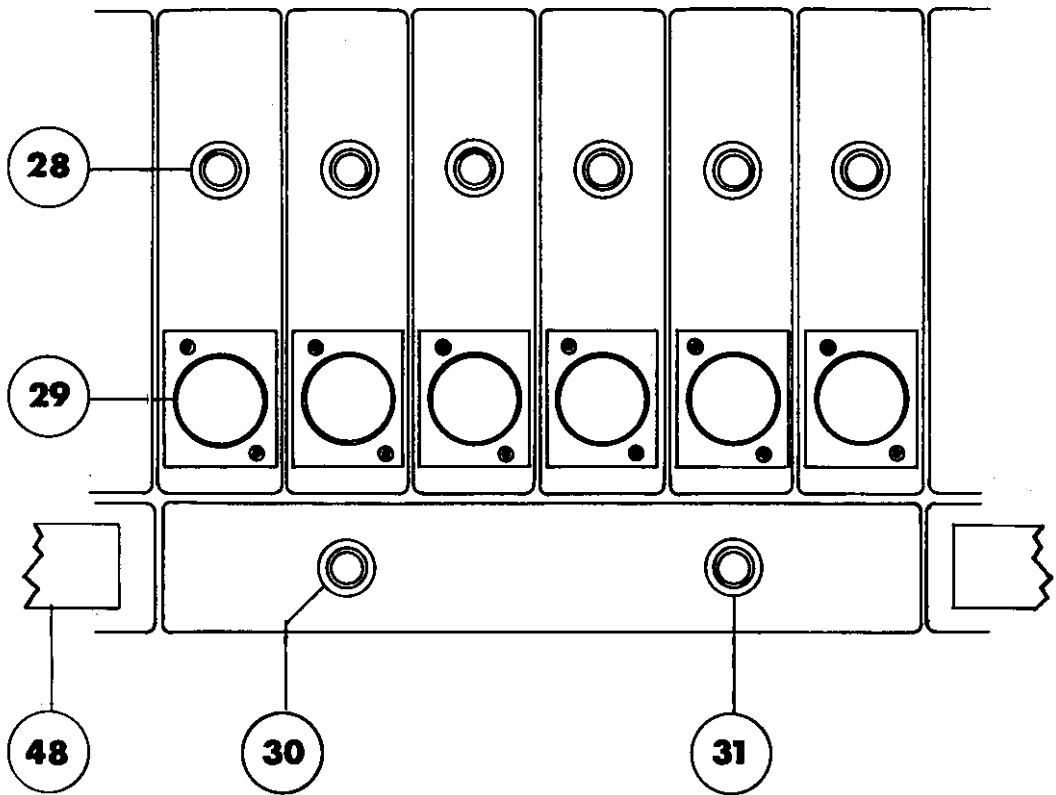

power and/or modulation. The **effects** (36) and **reverb** (38) **busses** have unbalanced outputs from their respective jacks on the rear panel. As an added feature, the 800S features a separate **stereo tape recording output jack** (34) to allow simultaneous taping during a performance when used as a sound reinforcement mixer.

The auxiliary inputs for **left** (39), **right** (40), **monitor** (41), **effects** (42), and **reverb** (43), are located on the rear panel and are standard 1/4" phone jacks. The level into these jacks should not be more than 2 Volts RMS nor less than 0.5 Volts RMS and must have adequate capability (output impedance) to drive 10,000 Ohms.

The **left line outputs**, (32) and (33), provide both a **transformer balanced** 600 Ohm output from a three pin XLR type connector as well as an unbalanced output @ 2K Ohm output impedance.

The **right line outputs**, (35) and (37), are similar to the left and have a similar output connector setup with a **transformer balanced 600 OHM** output as well as a 2K Ohm unbalanced output.

The **monitor output**, (46) and (47), are very similar in configuration to both the main channels and terminate in the same type of connectors: a three pin XLR and a standard phone jack.

The left, right, and monitor channels have the same output capabilities. The low impedance output is capable of +12 dbm (3 Volts RMS) while the unbalanced output is capable of 4 Volts RMS @ 2K Ohms output impedance. These levels are capable of driving most commercial power amplifiers or other auxiliary equipment to full performance by a wide margin and should allow a considerable amount of headroom in nearly any application.

The **effects output** terminates in a standard phone jack (36) and has an output capability of 2 Volts RMS @ 10K Ohm output impedance. The level presented at this output is controlled by the **effects level** (9) located on the front panel.

The **reverb output** terminates in a **standard phone jack** (38) and has a 2 Volt RMS output capability into 10K Ohm load. The level of this output is controlled by the **reverb level** (10) on the front panel.

The **Stereo Tape output jack** (34) is provided for your convenience in taping from the 800S mixer while all the other outputs are being used during a performance. The output level is the same as the left and right main and follows these levels as a "Sub-Out", thus presenting the tape machine with **exactly** the same relative balance between the channels as sent out in the program material going out from the left and right outputs.

The 800S is equipped with a type of power switch that enables the operator to easily reverse the polarity of the line (mains) cable thus yielding the ability to

minimize hum by proper polarization of the power supply (mains) connection. One of the **ON** positions will result in the lowest hum level and/or the least noise when unbalanced high impedance microphones are used and this switch position should be used.

You must properly polarize the power (mains) supply to achieve maximum performance in **each** location the mixer is used in.

SPECIAL NOTE..... Some Export versions of the 800S mixer do not have the two-way switch and this information should be disregarded for those models.

A heavy-duty power (mains) cable is provided for durability under road conditions. This is a three wire approved cord and it is **NOT** advisable to remove the ground pin under **any** circumstances. If you should find it necessary to operate the system where the proper three wire receptacles are **NOT** available, you should use a three-to-two wire adapter. These adapters are widely available and should be used instead of destroying the elaborate grounding facilities made possible by the three wire line (mains) cable.

For your convenience in traveling with the 800S, we have provided two cable wrapping brackets on the rear panel. Care should be taken to wind the power (mains) cable securely on these brackets before travel in order to avoid damage to the cable or to the bracket assemblies.

The 800S Mixer has two **meter set controls** (26) and (27) which enable the two VU meters to be adjusted for proper indication with any power amplifier, tape recorder, or other equipment driven by the mixer. If your power amp tape recorder etc. has VU meters the level set controls can be adjusted to track the 800S's VU meters with a constant input signal to each channel, i.e., set the 800S's meters to read "0" VU at the same signal level as the external equipment's VU does. With equipment that has LED overload indicators, the 800S's meters should be set to zero VU at the point where the LED peak indicator initially lights up.

If the equipment being fed by the 800S has no maximum level indicator you should refer any adjustment of VU meters to a properly equipped sound technician to avoid possible problems in matching VU readings with maximum output and/or modulation.

You should be aware that we have designed the 800S mixer to be able to drive power amplifiers with **VERY** low input sensitivities of 2 volts or higher. Because of the high output capability of the 800S, it may appear that the 800S is excessively noisy when plugged into power amplifiers with high input sensitivity such as the PEAHEY 260 or 800 Boosters which require only 1/2 volt for **FULL** output. The extra gain designed into the 800S to allow use with the less sensitive power amps should **NOT** be interpreted as poor design but as additional gain capability. It is possible to use "high gain" power amps with very good results by generally using less channel and master gain, or by decreasing the power amps sensitivity by turning down the power amp's level controls.

PEAVEY ELECTRONICS CORP.

MERIDIAN, MISSISSIPPI 39301

Printed in U.S.A.