

BOARD OF STUDIES
NEW SOUTH WALES

2009

**HIGHER SCHOOL CERTIFICATE
EXAMINATION**

Mathematics Extension 1

General Instructions

- Reading time – 5 minutes
- Working time – 2 hours
- Write using black or blue pen
- Board-approved calculators may be used
- A table of standard integrals is provided at the back of this paper
- All necessary working should be shown in every question

Total marks – 84

- Attempt Questions 1–7
- All questions are of equal value

Total marks – 84

Attempt Questions 1–7

All questions are of equal value

Answer each question in a SEPARATE writing booklet. Extra writing booklets are available.

Question 1 (12 marks) Use a SEPARATE writing booklet.

- (a) Factorise $8x^3 + 27$. **2**
- (b) Let $f(x) = \ln(x - 3)$. What is the domain of $f(x)$? **1**
- (c) Find $\lim_{x \rightarrow 0} \frac{\sin 2x}{x}$. **1**
- (d) Solve the inequality $\frac{x + 3}{2x} > 1$. **3**
- (e) Differentiate $x \cos^2 x$. **2**
- (f) Using the substitution $u = x^3 + 1$, or otherwise, evaluate $\int_0^2 x^2 e^{x^3+1} dx$. **3**

Question 2 (12 marks) Use a SEPARATE writing booklet.

- (a) The polynomial $p(x) = x^3 - ax + b$ has a remainder of 2 when divided by $(x - 1)$ and a remainder of 5 when divided by $(x + 2)$. **3**

Find the values of a and b .

- (b) (i) Express $3 \sin x + 4 \cos x$ in the form $A \sin(x + \alpha)$ where $0 \leq \alpha \leq \frac{\pi}{2}$. **2**

- (ii) Hence, or otherwise, solve $3 \sin x + 4 \cos x = 5$ for $0 \leq x \leq 2\pi$. Give your answer, or answers, correct to two decimal places. **2**

- (c) The diagram shows points $P(2t, t^2)$ and $Q(4t, 4t^2)$ which move along the parabola $x^2 = 4y$. The tangents to the parabola at P and Q meet at R .

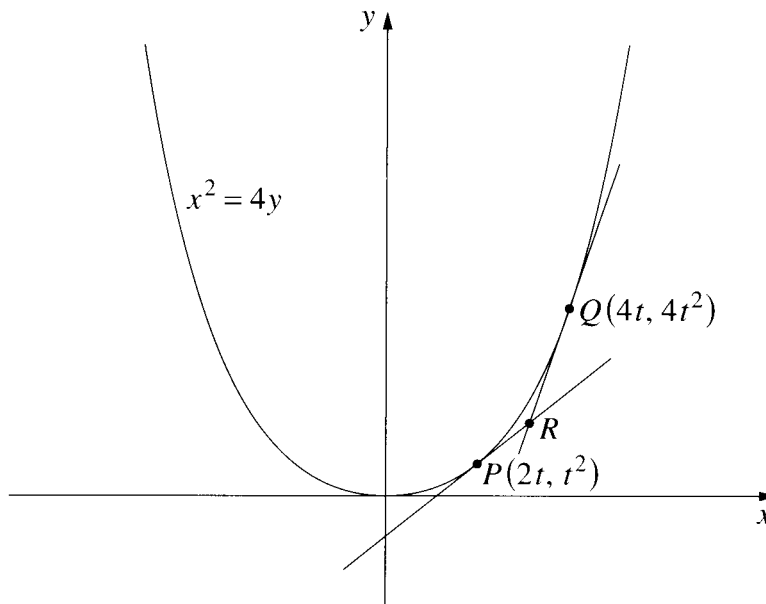

NOT TO
SCALE

- (i) Show that the equation of the tangent at P is $y = tx - t^2$. **2**
- (ii) Write down the equation of the tangent at Q , and find the coordinates of the point R in terms of t . **2**
- (iii) Find the Cartesian equation of the locus of R . **1**

Question 3 (12 marks) Use a SEPARATE writing booklet.

- (a) Let $f(x) = \frac{3 + e^{2x}}{4}$.
- (i) Find the range of $f(x)$. **1**
- (ii) Find the inverse function $f^{-1}(x)$. **2**
- (b) (i) On the same set of axes, sketch the graphs of $y = \cos 2x$ and $y = \frac{x+1}{2}$, for $-\pi \leq x \leq \pi$. **2**
- (ii) Use your graph to determine how many solutions there are to the equation $2 \cos 2x = x + 1$ for $-\pi \leq x \leq \pi$. **1**
- (iii) One solution of the equation $2 \cos 2x = x + 1$ is close to $x = 0.4$. Use one application of Newton's method to find another approximation to this solution. Give your answer correct to three decimal places. **3**
- (c) (i) Prove that $\tan^2 \theta = \frac{1 - \cos 2\theta}{1 + \cos 2\theta}$ provided that $\cos 2\theta \neq -1$. **2**
- (ii) Hence find the exact value of $\tan \frac{\pi}{8}$. **1**

Question 4 (12 marks) Use a SEPARATE writing booklet.

- (a) A test consists of five multiple-choice questions. Each question has four alternative answers. For each question only one of the alternative answers is correct.

Huong randomly selects an answer to each of the five questions.

- (i) What is the probability that Huong selects three correct and two incorrect answers? **2**
- (ii) What is the probability that Huong selects three or more correct answers? **2**
- (iii) What is the probability that Huong selects at least one incorrect answer? **1**

- (b) Consider the function $f(x) = \frac{x^4 + 3x^2}{x^4 + 3}$.

- (i) Show that $f(x)$ is an even function. **1**
- (ii) What is the equation of the horizontal asymptote to the graph $y = f(x)$? **1**
- (iii) Find the x -coordinates of all stationary points for the graph $y = f(x)$. **3**
- (iv) Sketch the graph $y = f(x)$. You are not required to find any points of inflexion. **2**

Question 5 (12 marks) Use a SEPARATE writing booklet.

- (a) The equation of motion for a particle moving in simple harmonic motion is given by

$$\frac{d^2x}{dt^2} = -n^2x$$

where n is a positive constant, x is the displacement of the particle and t is time.

- (i) Show that the square of the velocity of the particle is given by **3**

$$v^2 = n^2(a^2 - x^2)$$

where $v = \frac{dx}{dt}$ and a is the amplitude of the motion.

- (ii) Find the maximum speed of the particle. **1**
- (iii) Find the maximum acceleration of the particle. **1**
- (iv) The particle is initially at the origin. Write down a formula for x as a function of t , and hence find the first time that the particle's speed is half its maximum speed. **2**

Question 5 continues on page 7

Question 5 (continued)

- (b) The cross-section of a 10 metre long tank is an isosceles triangle, as shown in the diagram. The top of the tank is horizontal.

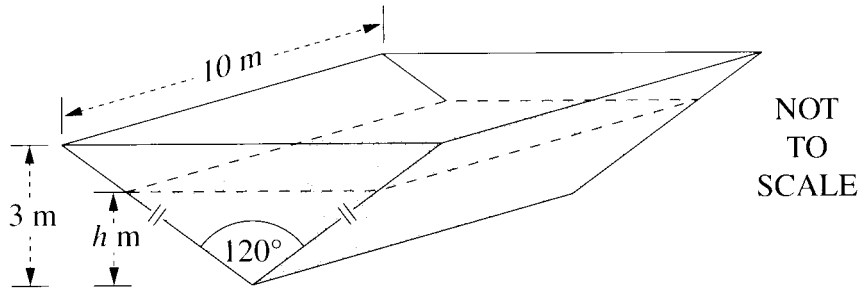

When the tank is full, the depth of water is 3 m. The depth of water at time t days is h metres.

- (i) Find the volume, V , of water in the tank when the depth of water is h metres. 1

- (ii) Show that the area, A , of the top surface of the water is given by 1

$$A = 20\sqrt{3}h.$$

- (iii) The rate of evaporation of the water is given by 2

$$\frac{dV}{dt} = -kA,$$

where k is a positive constant.

Find the rate at which the depth of water is changing at time t .

- (iv) It takes 100 days for the depth to fall from 3 m to 2 m. Find the time taken for the depth to fall from 2 m to 1 m. 1

End of Question 5

Question 6 (12 marks) Use a SEPARATE writing booklet.

- (a) Two points, A and B , are on cliff tops on either side of a deep valley. Let h and R be the vertical and horizontal distances between A and B as shown in the diagram. The angle of elevation of B from A is θ , so that $\theta = \tan^{-1}\left(\frac{h}{R}\right)$.

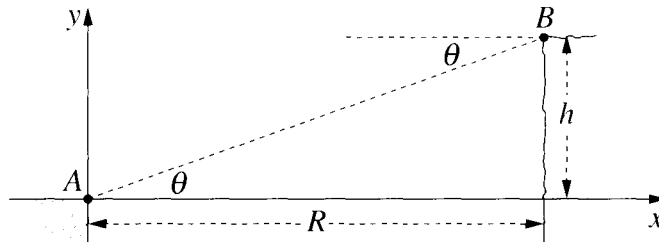

At time $t = 0$, projectiles are fired simultaneously from A and B . The projectile from A is aimed at B , and has initial speed U at an angle θ above the horizontal. The projectile from B is aimed at A and has initial speed V at an angle θ below the horizontal.

The equations for the motion of the projectile from A are

$$x_1 = Ut \cos \theta \quad \text{and} \quad y_1 = Ut \sin \theta - \frac{1}{2}gt^2,$$

and the equations for the motion of the projectile from B are

$$x_2 = R - Vt \cos \theta \quad \text{and} \quad y_2 = h - Vt \sin \theta - \frac{1}{2}gt^2.$$

(Do NOT prove these equations.)

- (i) Let T be the time at which $x_1 = x_2$. 1

Show that $T = \frac{R}{(U + V)\cos\theta}$.

- (ii) Show that the projectiles collide. 2

- (iii) If the projectiles collide on the line $x = \lambda R$, where $0 < \lambda < 1$, show that 1

$$V = \left(\frac{1}{\lambda} - 1\right)U.$$

Question 6 continues on page 9

Question 6 (continued)

- (b) (i) Sum the geometric series

3

$$(1+x)^r + (1+x)^{r+1} + \dots + (1+x)^n$$

and hence show that

$$\binom{r}{r} + \binom{r+1}{r} + \dots + \binom{n}{r} = \binom{n+1}{r+1}.$$

- (ii) Consider a square grid with n rows and n columns of equally spaced points.

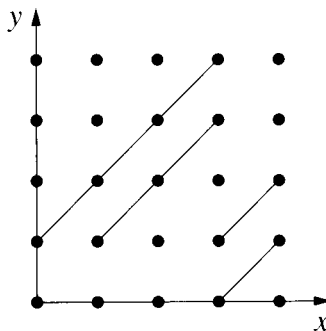

The diagram illustrates such a grid. Several intervals of gradient 1, whose endpoints are a pair of points in the grid, are shown.

- (1) Explain why the number of such intervals on the line $y=x$ is equal to $\binom{n}{2}$.

1

- (2) Explain why the total number, S_n , of such intervals in the grid is given by

1

$$S_n = \binom{2}{2} + \binom{3}{2} + \dots + \binom{n-1}{2} + \binom{n}{2} + \binom{n-1}{2} + \dots + \binom{3}{2} + \binom{2}{2}.$$

- (iii) Using the result in part (i), show that

3

$$S_n = \frac{n(n-1)(2n-1)}{6}.$$

End of Question 6

Question 7 (12 marks) Use a SEPARATE writing booklet.

(a) (i) Use differentiation from first principles to show that $\frac{d}{dx}(x) = 1$. **1**

(ii) Use mathematical induction and the product rule for differentiation to prove that $\frac{d}{dx}(x^n) = nx^{n-1}$ for all positive integers n . **2**

(b) A billboard of height a metres is mounted on the side of a building, with its bottom edge h metres above street level. The billboard subtends an angle θ at the point P , x metres from the building.

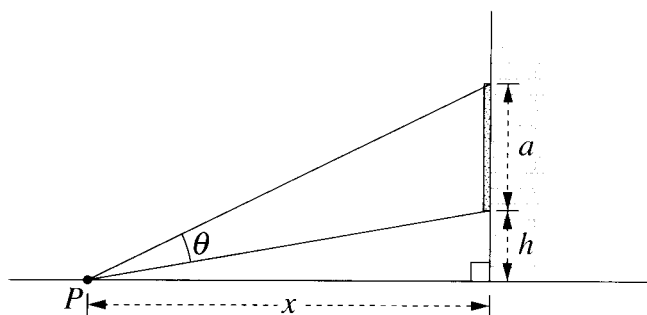

(i) Use the identity $\tan(A - B) = \frac{\tan A - \tan B}{1 + \tan A \tan B}$ to show that **2**

$$\theta = \tan^{-1} \left[\frac{ax}{x^2 + h(a + h)} \right].$$

(ii) The maximum value of θ occurs when $\frac{d\theta}{dx} = 0$ and x is positive. **3**

Find the value of x for which θ is a maximum.

Question 7 continues on page 11

Question 7 (continued)

- (c) Consider the billboard in part (b). There is a unique circle that passes through the top and bottom of the billboard (points Q and R respectively) and is tangent to the street at T .

Let ϕ be the angle subtended by the billboard at S , the point where PQ intersects the circle.

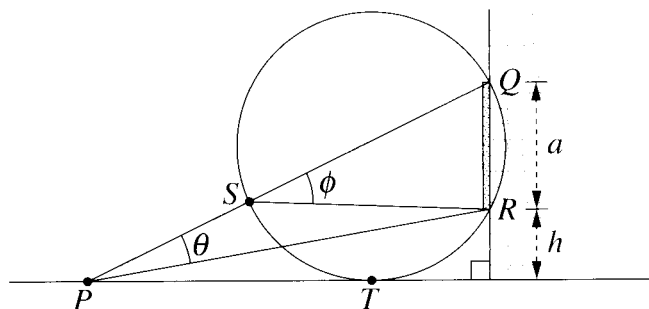

Copy the diagram into your writing booklet.

- (i) Show that $\theta < \phi$ when P and T are different points, and hence show that θ is a maximum when P and T are the same point. 3
- (ii) Using circle properties, find the distance of T from the building. 1

End of paper

STANDARD INTEGRALS

$$\int x^n dx = \frac{1}{n+1} x^{n+1}, \quad n \neq -1; \quad x \neq 0, \text{ if } n < 0$$

$$\int \frac{1}{x} dx = \ln x, \quad x > 0$$

$$\int e^{ax} dx = \frac{1}{a} e^{ax}, \quad a \neq 0$$

$$\int \cos ax dx = \frac{1}{a} \sin ax, \quad a \neq 0$$

$$\int \sin ax dx = -\frac{1}{a} \cos ax, \quad a \neq 0$$

$$\int \sec^2 ax dx = \frac{1}{a} \tan ax, \quad a \neq 0$$

$$\int \sec ax \tan ax dx = \frac{1}{a} \sec ax, \quad a \neq 0$$

$$\int \frac{1}{a^2 + x^2} dx = \frac{1}{a} \tan^{-1} \frac{x}{a}, \quad a \neq 0$$

$$\int \frac{1}{\sqrt{a^2 - x^2}} dx = \sin^{-1} \frac{x}{a}, \quad a > 0, \quad -a < x < a$$

$$\int \frac{1}{\sqrt{x^2 - a^2}} dx = \ln \left(x + \sqrt{x^2 - a^2} \right), \quad x > a > 0$$

$$\int \frac{1}{\sqrt{x^2 + a^2}} dx = \ln \left(x + \sqrt{x^2 + a^2} \right)$$

NOTE : $\ln x = \log_e x, \quad x > 0$